

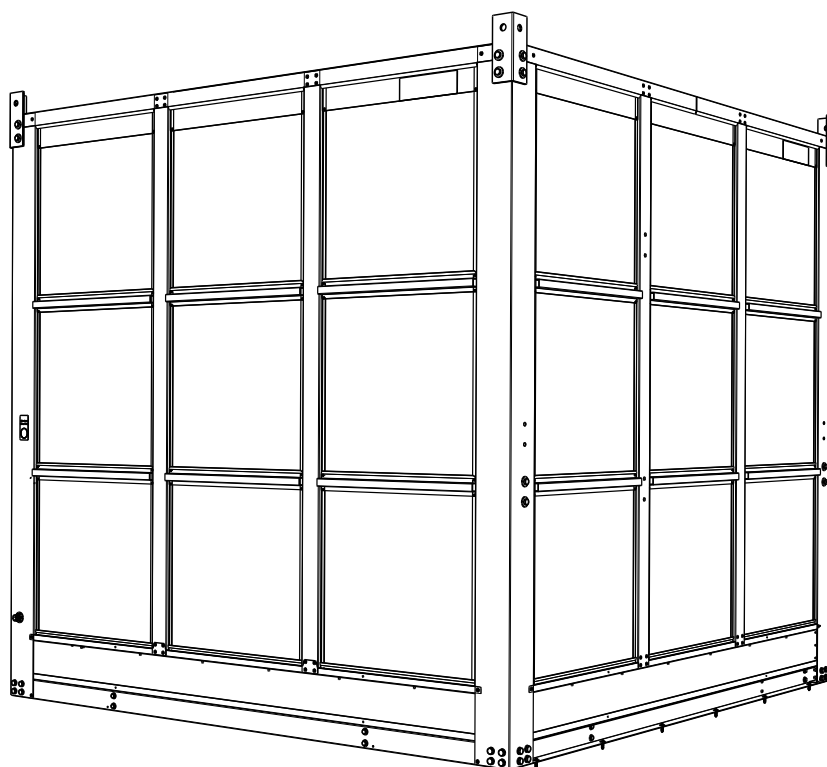

INSTALLATION & OPERATION MANUAL

RPXL EVAPORATIVE COOLER



ORIGINAL ENGLISH INSTRUCTIONS

TABLE OF CONTENTS

IMPORTANT SAFETY INSTRUCTIONS	4	MAINTENANCE SCHEDULE	19
COOLER VIEWS	6	MAINTENANCE FREQUENCY	19
COOLER CONTENTS	8	WINTER OPERATION AND SHUTDOWN	19
INSTALLATION COMPONENTS	8	MAINTENANCE SAFETY	19
OPTIONAL COMPONENTS	8	MAINTENANCE CHECKLIST	20
TECHNICAL DESCRIPTION	9	MAINTENANCE INSTRUCTIONS	22
TRANSPORT	9	INSPECTION PROCEDURES	22
MOVING THE COOLER	9	PUMP	22
LIFTING THE COOLER	9	WATER PROBE	22
UNPACKING THE COOLER	9	WATER RESERVOIR (TANK)	22
EQUIPMENT RECEIPT	9	COOLING PADS	22
INSTALLATION	10	FAN BELT	23
COOLER LOCATION	10	PULLEYS & TAPERLOCKS	23
BUILDING EXHAUST RELIEF OPENINGS	10	BEARING LUBRICATION	23
LOCATING INSIDE OF PLANT ROOMS	10	WARRANTY TERMS	24
ACCESS FOR SERVICING AND MAINTENANCE	10	APPENDIX A	27
MOUNTING/SUPPORT	11		
SUPPLY AIR DUCT CONNECTIONS	11		
FITTING AND REMOVING PAD FRAMES	11		
ELECTRICAL REQUIREMENTS	12		
ELECTRICAL SUPPLY INSTALLATION	12		
MOTOR LOCKED-ROTOR PROTECTION	12		
ELECTRICAL POWER CABLES	12		
COOLER CONTROLS	12		
WATER REQUIREMENTS	13		
WATER SUPPLY INSTALLATION	13		
WATER SUPPLY PRESSURE REGULATION	13		
WATER SUPPLY ISOLATION	13		
WATER SUPPLY FILTRATION	13		
WATER HAMMER	13		
WATER FLOAT VALVE	13		
WATER DRAIN INSTALLATION	14		
WATER FLOW RESTRICTOR TAP	14		
WATER BLEED CONTROL	14		
OPTIONAL WATER MANAGER KIT	14		
COMMISSIONING	15		
INSTALLATION CHECKLIST	15		
FAN BELT CHECK	16		
FAN RUN CHECK	16		
WATER LEVEL CHECK	16		
COOLING PAD FLUSH & DRAIN	16		
SET WATER BLEED RATE	16		
COOLING PAD SATURATION CHECKS	17		
CUSTOMER HANDOVER CHECKLIST	17		
TROUBLESHOOTING	18		

WARNING! FAILURE TO INSTALL AND COMMISSION THE PRODUCT IN COMPLIANCE WITH THESE INSTRUCTIONS, OR FAILURE TO DO THE JOB PROPERLY AND COMPETENTLY, MAY VOID THE CUSTOMER'S WARRANTY. FURTHER, IT COULD EXPOSE THE INSTALLER AND/OR THE RETAILER TO SERIOUS LIABILITY.

IMPORTANT SAFETY INSTRUCTIONS

READ AND SAVE THESE INSTRUCTIONS FOR FUTURE REFERENCE.

FOR EUROPE

This appliance can be used by children aged from 8 years and above and persons with reduced physical, sensory or mental capabilities or lack of experience and knowledge if they have been given supervision or instruction concerning use of the appliance in a safe way and understand the hazards involved. Children shall not play with the appliance. Cleaning and user maintenance shall not be made by children without supervision.

FOR AUSTRALIA, NEW ZEALAND & OTHER NON-EUROPEAN COUNTRIES

This appliance is not intended for use by persons (including children) with reduced physical, sensory or mental capabilities, or lack of experience and knowledge, unless they have been given supervision or instruction concerning use of the appliance by a person responsible for their safety. Children should be supervised to ensure that they do not play with the appliance.

Means for all pole disconnection must be incorporated in the fixed wiring in accordance with the wiring rules.

If the supply cord is damaged, it must be replaced by the manufacturer, its service agent or similarly qualified persons in order to avoid a hazard.

The following specifications for the cooler water supply are required:

Min Water Pressure: 100kPa (15psi)

Max Water Pressure: 800kPa (115psi)

New hose sets supplied with the appliance are to be used and old hose-sets should not be re-used.

WARNING - TO REDUCE THE RISK OF FIRE, ELECTRIC SHOCK, OR INJURY TO PERSONS, OBSERVE THE FOLLOWING:

- a) Use this unit only in the manner intended by the manufacturer. If you have questions, contact the manufacturer.
- b) Before servicing or cleaning unit, switch power off at service panel and lock the service disconnecting means to prevent power from being switched on accidentally. When the service disconnecting means cannot be locked, securely fasten a prominent warning device, such as a tag, to the service panel.
- c) Installation work and electrical wiring must be done by qualified person(s) in accordance with all applicable codes and standards, including fire-rated construction.
- d) When cutting or drilling into wall or ceiling, do not damage electrical wiring and other hidden utilities.
- e) Ducted fans must always be vented to the outdoors.
- f) Do not use this fan with any solid-state speed control device.
- g) Do not use replacement parts that have not been recommended by the manufacturer (e.g. parts made at home using a 3D printer).

FOR AUSTRALIAN BUSHFIRE PRONE AREAS

WARNING: This cooler is NOT APPROVED for installation in any bushfire zoned area/property (BAL-12.5 to BAL-FZ).

IMPORTANT SAFETY INSTRUCTIONS

EMPLOYER AND EMPLOYEE RESPONSIBILITIES

The installation and maintenance of evaporative coolers at height has the potential to create Occupational Health and Safety issues for those involved. Installers are advised to ensure they are familiar with the relevant State and Federal legislation, such as Acts, Regulations, approved Codes of Practice and Australian Standards, which offer practical guidance on these health and safety issues. Compliance with these regulations will require appropriate work practices, equipment, training and qualifications of workers.

Seeley International provides the following information as a guide to contractors and employees to assist in minimising risk whilst working at height.

INSTALLER AND MAINTENANCE CONTRACTORS - RISK ASSESSMENT

A risk assessment of all hazardous tasks is required under legislation. A risk assessment is an essential element that should be conducted before the commencement of work, to identify and eliminate the risk of falls or to minimise these risks by implementing control measures. There is no need for this to be a complicated process, it just is a matter of looking at the job to be done and considering what action(s) are necessary so the person doing the job does not injure themselves.

This should be considered in terms of:

- What are the chances of an incident happening?
- What could the possible consequence be?
- What can you do to reduce, or better still, completely get rid of the risk?

SOME POINTS TO CONSIDER

- What is the best and safest access to the roof and working areas?
- If a worker is alone, who knows they are there and if they get into difficulty, how can they summon help? (Call someone on the ground? Mobile phone? etc.)
- What condition is the roof in? Should the trusses, underside or surface be checked?
- Does the worker have appropriate foot wear? (Flat sole jogger type is advisable.)
- Are all power cables / extension leads safe and appropriately rated?
- Are all ladders, tools and equipment suitable in good condition?
- Where ladders are to be used, is there a firm, stable base for them to stand on? Can they be tied or secured in some way at the top? Is the top of the ladder clear of electricity supply cables?
- Is there a roof anchor to attach a harness and lanyard to? If so, instruction should be issued for the use of an approved harness or only suitably trained people used.
- Are all tools and materials being used, prevented from slipping and falling onto a person at ground level? Is the area below the work area suitably protected to prevent persons walking in this area?
- Does the work schedule take into account weather conditions, allowing for work to be suspended in high winds, thunderstorms/lightning or other types of weather giving wet, slippery surfaces?
- Is there an on-going safety check system of harnesses, ropes, ladders and access/lifting equipment and where they exist on roofs, anchor points before the commencement of work?
- Is there a system which prevents employees from working on roofs if they are unwell or under the influence of drugs or alcohol?

- Are there any special conditions to consider i.e. excessive roof pitch, limited ground area, fragile roof, electrical power lines?

OTHER IMPORTANT REQUIREMENTS

- Never force parts to fit because all parts are designed to fit together easily without undue force.
- Never drill holes in the tank of the cooler.
- Check the proposed cooler location, to ensure that it is structurally capable of supporting the weight of the cooler, or provide an adequate alternate load bearing structure.
- Ensure the installation complies with all local and national regulations with regards to electrical, plumbing and bushfire construction requirements.
- In areas where temperatures can cause water supply pipes to freeze, a drain down facility should be provided during the installation. This drain down facility must be activated prior to freezing conditions, to avoid possible damage to the cooler components.
- Details on how to register your product warranty can be found near the end of this manual.

MAINTENANCE NOTE

As with any product that has moving parts or is subject to wear and tear, it is VERY IMPORTANT that you maintain the product and have it regularly serviced. It is a condition of warranty cover for your product that you comply with all of the maintenance and service requirements set out in this manual. Compliance with these requirements will prolong the life of your product. Further, it is also a condition of warranty cover that each item in the Maintenance Schedule in this manual is performed with the frequency indicated, by a qualified, licensed technician, and that the Maintenance Schedule is properly filled out (ie names, signature, date, and action taken) when the item is completed.

ANY FAILURE TO CARRY OUT THE REQUIRED MAINTENANCE AND SERVICING REQUIREMENTS, AND ANY FAILURE TO PROPERLY FILL OUT THE MAINTENANCE SCHEDULE, WILL VOID YOUR WARRANTY.

COOLER VIEWS

ISOMETRIC

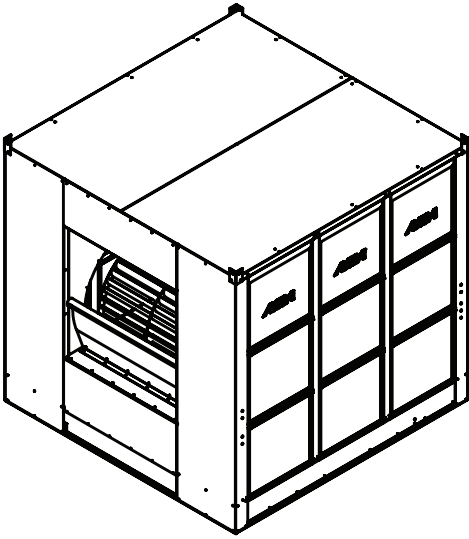

TOP

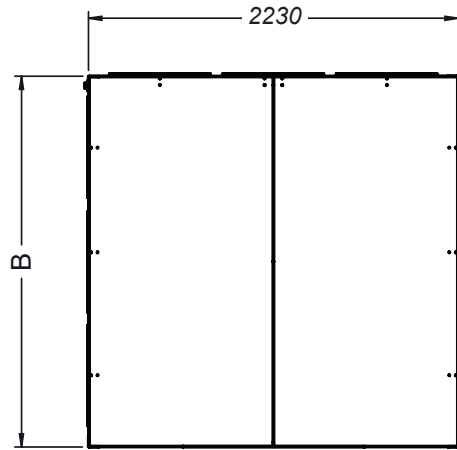

REAR

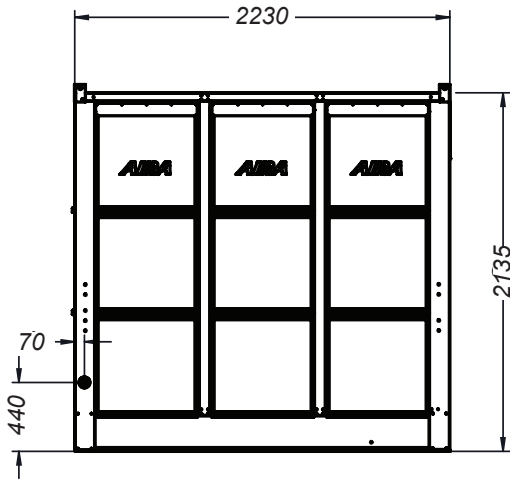

SIDE

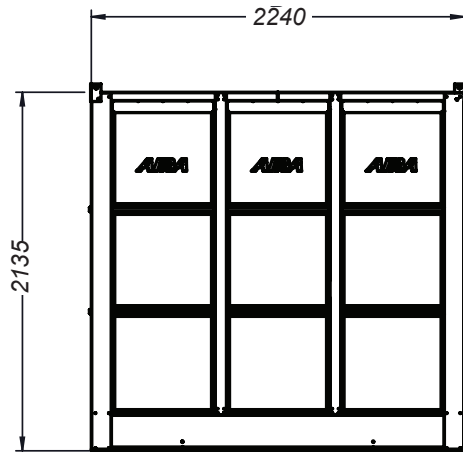

FRONT

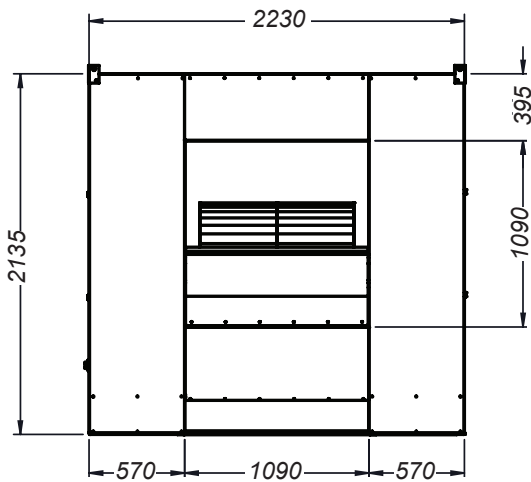

BOTTOM

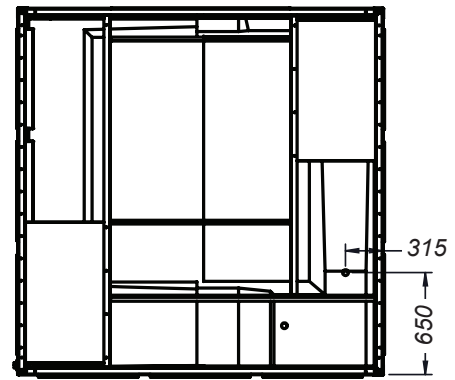

Drain Location

Side Discharge option shown.
Dimensions are in mm

COOLER CONTENTS

INSTALLATION COMPONENTS

Item	Seeley Part	Description	QTY
1A	859757	Installation, Operation, Maintenance Manual	1
1B	639860	Setting Water Flow Rates Instructions	1
2	804415L	O'Ring BS128 38IDx2.6 N70	1
3	608884	Overflow Tube	1
4	200105	Rubber Washer 58x48	1
5	935409	Nut & Bush	1
6A	803132	Switch Cover Plate	1
6B	200103	Controls Mounting Block	1
6C	RPA919	Switch Mechanism	3
7	627472	Electrical Isolation Switch	

ITEM 1A

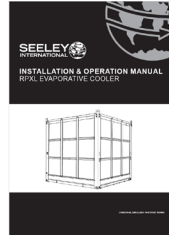

ITEM 2



ITEM 3



ITEM 4



ITEM 5

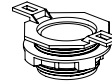

ITEM 6



ITEM 7



OPTIONAL COMPONENTS

Item	Seeley Part	Description
1	077444	Water Manager Kit
2	275581	Roof Stand Kit RPXL

ITEM 1

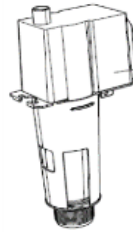

TECHNICAL DESCRIPTION

RPXL units are Direct Evaporative Coolers. Water is pumped from the internal reservoir and dispersed through the Chillcel® cooling pads fitted to the sides of the cooler. The centrally located fan draws hot outside air through the saturated cooling pads, where, through evaporation, it is cooled, before being fed into the customer's ductwork.

RPXL is available in 2 different airflow capacities with the option Down (D), Side (S) or Top (T) discharge directions.

The fan is belt driven by a 2-speed induction motor.

The cooler is supplied with switch plate controls offering independent control for the fan speed and cooling functions.

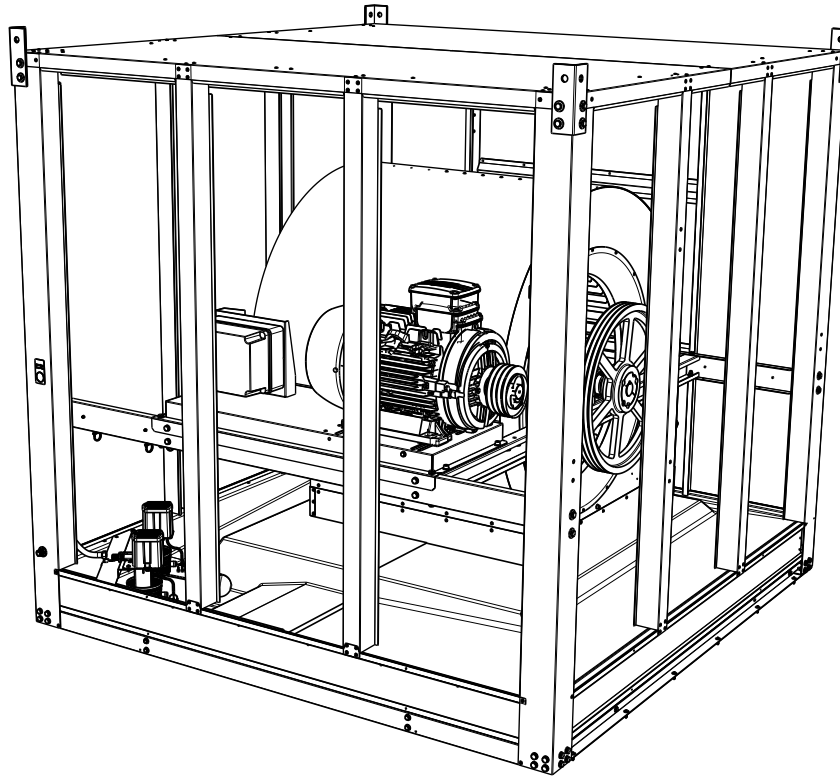

TRANSPORT

MOVING THE COOLER

The cooler can be moved either by fork-truck or pallet-truck whilst it is resting on its dedicated pallet. Do not drag the cooler unless it is on its dedicated pallet. Always forklift from the same side as the motor.

The cooler may be strapped down with slings over the top of the cabinet body. To avoid any damage to the cabinet, always use corner protection and braces.

Do not double stack coolers. Transport and store as 'Top Load Only'.

LIFTING THE COOLER

The cooler may be lifted by a crane using the designated lifting eyes. It is recommended to use a spreader bar.

Lifting eyes must be inspected prior to lifting to ensure all bolts are present, free from damage and securely screwed in place. If any damage is observed, lifting eyes should be replaced.

Do not attempt to lift using any cabinet features or by retrofitting lifting lugs. The cabinet may be damaged and/or lift safety compromised. The designated lifting eyes are designed to lift cooler dry weight only.

UNPACKING THE COOLER

The cooler will be delivered on a dedicated pallet and will be wrapped in plastic film which will need to be removed before installation.

A small box containing components that are required for installation can be found inside the cooler.

EQUIPMENT RECEIPT

Inspect the cooler for any damage caused in transit. Any such damage must be immediately reported to the shipper of the goods.

The unit has been factory tested to check for correct operation of all components. If any part is missing or damaged, notify the supplier immediately.

INSTALLATION

COOLER LOCATION

Check the proposed cooler location to ensure that it is structurally capable of supporting the weight of the cooler, or provide an adequate alternate load bearing structure.

Model	Shipping Weight	Operating Weight
RPXL16000	685 kg	740 kg
RPXL18000	730 kg	785 kg

Carefully consider neighbouring properties and noise levels when locating the cooler, if necessary talk to the customer and the neighbour before carrying out the installation.

Always locate the cooler where it will receive a plentiful supply of fresh air and not in a recess where it may be starved for air or where the air is polluted. Provision must be made for access to electricity, water supplies and drains.

Ensure the cooler location is a minimum of:

- 3.0m (10') from a solid fuel heater flue
- 1.5m (5') from a gas flue
- 1.2m (4') away from adjacent solar panels or similar roof mounted fixtures
- 6.0m (20') from a sewer vent
- 600mm (2') from a wall.
- 3.0m (10') (preferably 5.0m (17')) away from any TV antenna or antenna cables. Make sure the cooler is not between the antenna and the transmission tower that is providing the television signal to the home.

BUILDING EXHAUST RELIEF OPENINGS

Evaporative coolers operate on 100% fresh outside air and, to provide efficient cooling or ventilation, there must be sufficient exhaust relief openings to the outside of the building.

Relief openings can be via open doors, windows or vents. Allow approximately 0.4m² per 1000l/s of supply air. If fly wire screens are fitted to the relief area, allow up to 0.8m² per 1000l/s.

Select relief openings to provide the best pattern of cool air flow through the building. For example, open windows and doors that are farthest from the outlet vent in each room. Note that relief openings may be ineffective if exposed to high winds.

Where the design of the building prevents adequate exhaust relief openings, consideration should be given to the provision of mechanical extractions, such as an exhaust fan.

LOCATING INSIDE OF PLANT ROOMS

IMPORTANT! If the cooler is placed inside a plant room, installers must ensure that a sufficient volume of outside airflow is entering the plant room to prevent harmful emissions produced by other nearby appliances being drawn into the cooler and delivered into the building.

ACCESS FOR SERVICING AND MAINTENANCE

The cooler should be installed in a position that allows adequate access for installation, and future maintenance and servicing activities. This should comply with installation guidelines and any local, State and National regulations.

Consider the following for installation location:-

- Which has clear access to and around the cooler
- Which is clear of fixtures in line with below clearances
- Which is clear of fall edges (> 3m (10') away)
- Which is structurally capable of supporting the weight of the cooler and service technicians

Required clearances around and between coolers for future maintenance and servicing are shown below.

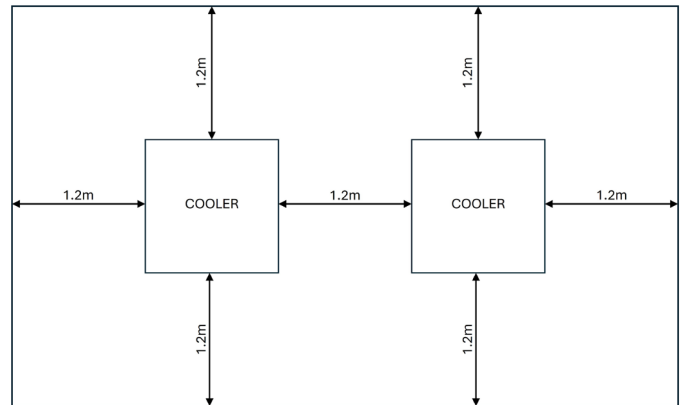

Extra service or warranty charges may apply for the cost of any equipment or additional labour involved in accessing the cooler if these guidelines are not met.

Note! Do you need to discuss the installation of items like safety anchor points with the customer?

INSTALLATION

MOUNTING/SUPPORT

The cooler is designed to be mounted onto a level platform which must be strong enough to support the operating weight of the cooler.

Roofstands, accommodating 0-10 degree roof pitches, are available for order via Seeley International. See Optional Components List.

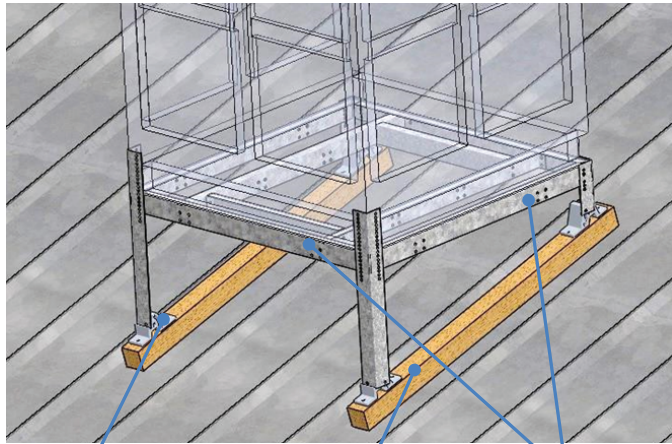

Self Levelling Feet

Compliant Support Bearer to suit roof structure

Check stand is level in both directions

The cooler base has a series of mounting holes for securing the cooler. Where necessary, installers should use a sufficient number of suitably rated vibration isolation mounts to support the operating mass of the cooler.

LEVELLING

It is important that the cooler is level in all directions. Coolers which are not level may cause reduced water pump flow rates and/or increased drain water overflow.

Ensure the top of the support structure is level and square in all directions (use a spirit level).

SUPPLY AIR DUCT CONNECTIONS

The cooler's supply air duct interface measures 1090 x 1090mm and locations are shown in the cooler views at the beginning of this manual.

Typical installations use ductmate flanges screwed to the face of the unit over the blower opening.

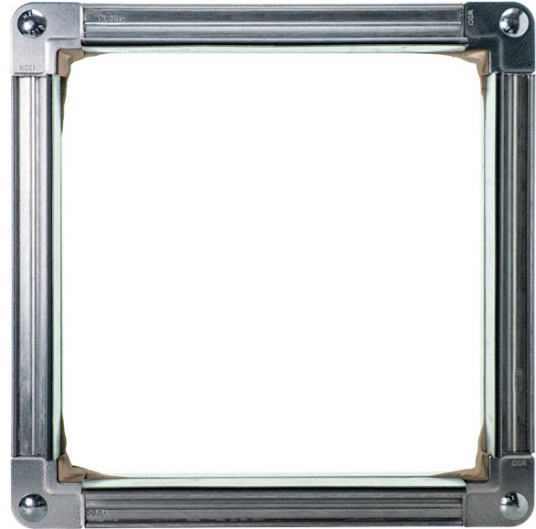

Ducts must be independently supported and suitably insulated to minimise temperature losses. All direction changes must utilise a generous radial turn with internal air directors to minimise turbulence and maximise efficiency.

IMPORTANT! Do not run the cooler against closed supply air ducts. Always ensure that dampers are fully open prior to starting the cooler fans.

FITTING AND REMOVING PAD FRAMES

To remove a pad frame, gently insert a flat head screw driver into one of the two recesses on the bottom of the frame.

Lever the frame upwards until the cooling pad is clear of the retention strip. Repeat on the other side of the frame.

Take hold of the pad frame, pivot the bottom outwards and pull down. Be careful not to damage the cooling pad.

To refit the frame to the unit, push the top of the frame in first lining up the cooling pads with the retention strip of the corner pillars. Once pads are lined up push in the bottom of the frame until the frame clicks into the lower retention strip.

ELECTRICAL REQUIREMENTS

ELECTRICAL SUPPLY INSTALLATION

INSTALLATION OF THE COOLER MUST CONFORM TO LOCAL ELECTRICAL RULES, REGULATIONS AND STANDARDS.

It is a requirement of Seeley International that all coolers be wired with a dedicated circuit and circuit breaker/fuse at the distribution board.

The cooler is supplied with a mains isolation switch which must be installed adjacent to the cooler.

See the cooler rating label for the correct electrical data. Before connecting, make sure the power supply matches the cooler voltage and frequency.

Electrical Supply Specification:

RPXL16000: 415V / 50 Hz / 3N~ / 32A

RPXL18000: 415V / 50 Hz / 3N~ / 34A

MOTOR LOCKED-ROTOR PROTECTION

As this cooler utilises a squirrel cage induction motor, the starting current (LRA) is significantly higher than the nominal current (FLA). Only use D-Curve circuit breakers to accommodate the high inrush current.

ELECTRICAL POWER CABLES

Pass all power cable through the cable knockouts located on the corner pillars.

Important! Ensure the mains cable is not submerged or touching the water in the reservoir at any point along its length.

COOLER CONTROLS

The cooler is supplied with switch plate controls offering independent control for the fan speed and cooling functions. Each cooler requires a dedicated switch plate. No group control is possible.

Control circuit wiring is via a 240V 4-wire system and it is the installer's responsibility to provide wiring back to the unit.

See Appendix A for the full cooler wiring diagram.

To run the cooler in VENT mode:

- Switch the AIR control to ON.
- Switch the COOL control to OFF.
- Switch the SPEED control to either LO or HI as required.

To run the cooler in COOL mode:

- Switch the AIR control to ON.
- Switch the COOL control to ON.
- Switch the SPEED control to either LO or HI as required.

To stop the cooler.

- Switch the AIR control to OFF.
- Switch the COOL control to OFF.



WATER REQUIREMENTS

WATER SUPPLY INSTALLATION

The cooler requires a permanent water supply to be connected.

INSTALLATION OF THE WATER SUPPLY MUST CONFORM TO LOCAL PLUMBING RULES, REGULATIONS AND STANDARDS.

The following specifications for water supply are required:

Water Connections:

½" BSP. Use flexible hose for the final connection to assist with future maintenance.

Water Supply:

100kPa (15psi) - 800 kPa (115psi)
10L/min (2.6 gal/min) MINIMUM
20L/min (5.3 gal/min) RECOMMENDED

Water Supply Temperature:

40°C (105°F) MAXIMUM

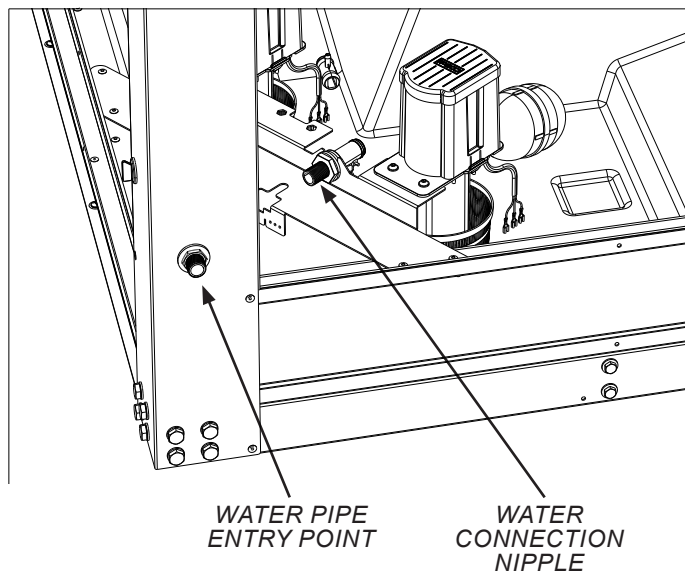

WATER SUPPLY PRESSURE REGULATION

The Installer must provide a pressure regulator in the water supply line adjacent to the cooler to regulate water supply pressures between 100kPa (15 PSI) and 800kPa (115 PSI).

Important! Water pressures which are lower than 100kPa (15 PSI) will prevent the inlet solenoid valve (if fitted) from opening.

Important! Water pressures which are higher than 1200 kPa (175 PSI) and/or water temperatures which are higher than 40°C (105°F) risk inlet solenoid valve (if fitted) failure.

Water pipes installed on the outside of a building, or any other exposed location, shall have adequate insulation to protect against freezing in the winter and solar radiation heating in the summer.

If a non-return valve is installed in the water supply line, it is recommended that a suitable pressure relief valve is also installed between the cooler and non-return valve to limit the pressure rise associated with the heating effects of ambient temperature and solar radiation.

WATER SUPPLY ISOLATION

The Installer must provide a manual 1/4 turn ball type shut off valve (do not use a stop cock) in the water supply line adjacent to the cooler, subject to local plumbing regulations. This allows the water supply to be isolated whenever work needs to be done on the cooler.

In areas where temperatures can cause water supply pipes to freeze, a drain down facility should be provided during the installation. This drain down facility must be activated prior to freezing conditions, to avoid possible damage to the cooler components.

WATER SUPPLY FILTRATION

It is recommended that the Installer provide an inlet water filter, with a minimum 500 microns mesh, in the water supply line, external to the cooler, to prevent any debris from entering and damaging cooler components.

Important! Flush the water pipe to remove any contaminants (swarf, filings or dirt) before final fitting. Contaminants can lodge in the inlet valve, preventing it from functioning correctly.

WATER HAMMER

Not all installation pipeworks are the same, and some may require additional prevention against water hammer.

If water hammer is a problem, it is the responsibility of the Installer to fit an appropriate water hammer arresting device external to the cooler.

WATER FLOAT VALVE

An internal float valve controls the water level inside the reservoir. The float valve must be set to maintain the water level a maximum of 10mm below the overflow level.

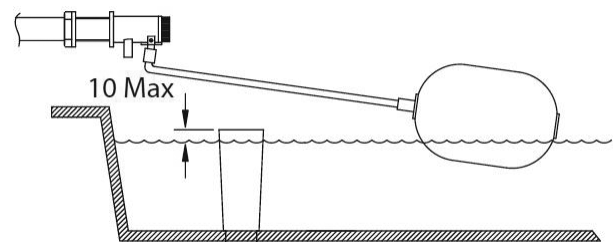

WATER REQUIREMENTS

WATER DRAIN INSTALLATION

The cooler requires a permanent water drain to be connected.

INSTALLATION OF THE WATER DRAIN MUST CONFORM TO LOCAL PLUMBING STANDARDS.

Drain Connections:

1.5" (40mm) BSP Male

The cooler installation kits contains components for an overflow pipe which must be fitted on-site.

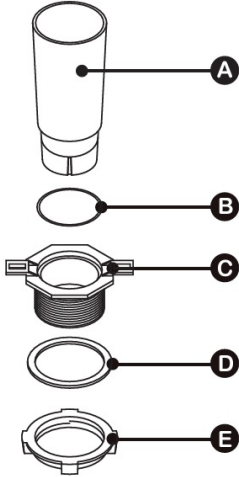

- A = Overflow Pipe
- B = O'Ring
- C = Threaded Bush
- D = Rubber Washer
- E = Lock Nut

ILL3994

Important! Water drained from the drain valve is high in salinity and must be carried away to a suitable discharge point on the building or property. Never drain the water directly onto the roof

WATER FLOW RESTRICTOR TAP

The cooler is fitted with a water flow restrictor taps located next to the pumps.

If the water flow rate to the cooling pads is too high, water draw-off or carryover will occur. In some cases, water droplets can be sucked into the fan and blown into the duct system.

If the water flow rate to the cooling pads is too low, they will not become saturated leading to poor cooling performance.

The aim is to have all the pads suitably damp but not flooded.

Follow the instructions in the Commissioning section to set the correct flow rate

Avoid Flooded Cooling Pads!

Over time, water carryover will result in excessive corrosion, and damage to electrical components in the cooler. Damage due to water carryover is not covered by warranty.

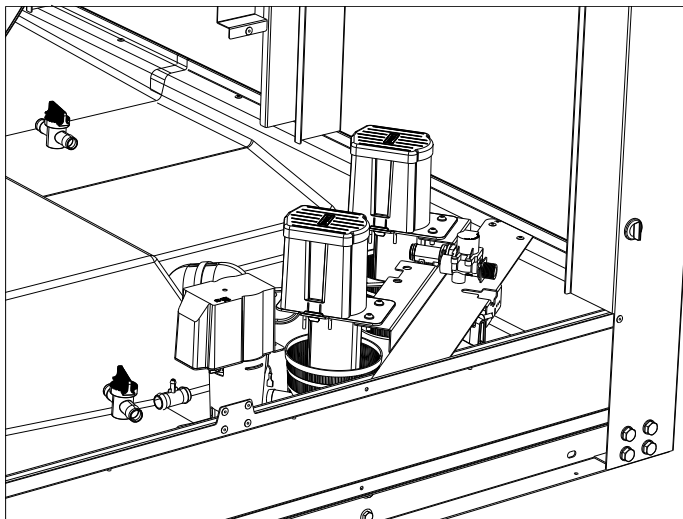

WATER BLEED CONTROL

When using the overflow pipe, it is essential to continuously bleed a small amount of water to reduce the accumulation of salts and minerals in the cooler.

Adjustment to the bleed rate is made by turning the bleed control tap to the desired setting. The bleed control tap is located externally on a corner pillar.

Important! Place the hose from the bleed tap into the overflow pipe. Ensure the tube cannot be pinched when replacing cooling pads.

Follow the instructions in the Commissioning section to set the recommended bleed rates.

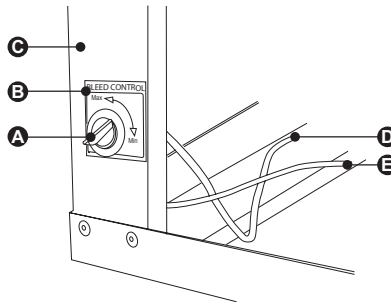

- A = Bleed Tap
- B = Min/Max Label
- C = Corner Pillar
- D = Supply Hose from Pump
- E = Bleed Hose to Drain

ILL4004

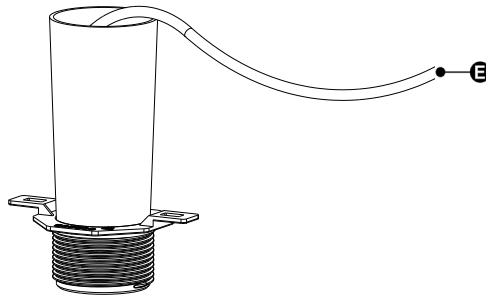

OPTIONAL WATER MANAGER KIT

An optional Water Manager Kit is available which contains an inlet water solenoid valve, water salinity probes, and an electric drain valve. When fitted, the overflow pipe and continuous bleed are not required.

Follow the instructions provided in the kit to fit the new components.

Important! Drainage systems with long pipe runs, multiple entry points, and/or incorporating traps shall use a tundish or similar device to create a 25mm (1") air-gap between the bottom of the drain valve and the drainage system.

As water evaporates from the Chillce[®] pads, the salinity of the remaining water naturally increases.

The water management system uses a 2-pin water probe to measure water conductivity as a proxy for salinity. Upon reaching a preset salinity level, the drain valve will open to let water out of the reservoir.

During a salinity drain cycle, the drain valve stays opens until the water level falls below the probe, after which the drain valve closes, and inlet solenoid valve opens to refill the reservoir with fresh water.

How often this process occurs depends upon the quality of the water supply and the rate of evaporation.

The salinity set point can be set to either 2300uS/cm, 4275uS/cm, or 6000uS/cm.

Changing between the different methods and set points is via DIP switches on the Water Manager control board.

COMMISSIONING

Owner Name: Dealer:
Address: Installer:
..... Date Installed:
Telephone: Model No:
Site Asset ID: Serial No:

INSTALLATION CHECKLIST

This checklist only covers the key points to be observed during installation. Always refer to the relevant sections of the installation manual for full details.

COOLER LOCATION

- The integrity of the roof structure has been assessed as being able to support the cooler weight.
- The cooler is adequately supported, secure, and level.
- The cooler is installed in a position that allows adequate access for future maintenance and servicing activities.
- The cooler will always receive a plentiful supply of fresh air.

SUPPLY AIR DROPPER/DUCTWORK

- Vibration absorbing flexible connections are used for all duct connections to the cooler.
- All building penetrations are correctly flashed and sealed.
- If flexible ducts are used, they are fully extended, hung correctly, with no kinks, tight bends, or squashed segments.
- All duct joints are fully sealed with no air leaks.
- The air balance for all outlets has been adjusted to the customer's satisfaction.

ELECTRICAL SUPPLY

- The electrical power supply installation adheres to all local and national regulations
- The electrical power supply is wired back to the distribution board on its own separate circuit.
- A mains isolation switch, with all pole disconnection, has been installed adjacent to the cooler.
- The owner has been instructed how to electrically isolate the unit in case of an emergency.
- The Phase-Phase voltage is within the Rating Label specification.

Record the details

3~ Voltage L1-L2

3~ Voltage L1-L3

3~ Voltage L2-L3

WATER SUPPLY

- The water supply installation adheres to all local and national regulations with no leaks at any fittings or valves.
- The water supply pipes were flushed of any foreign materials before connection to the cooler was made.
- The water is filtered as required.
- Static water pressure to each cooler is between 100kPa (15psi) and 800 kPa (115psi).
- Water flow rate to each cooler is greater than 10L/min (2.6 gal/min) when all coolers are filling.
- An isolation valve has been installed adjacent to the cooler.
- The owner has been instructed on how to isolate the water supply to the cooler in case of emergency.

Record the details

Water Pressure

WATER DRAIN

- The water drain installation adheres to all local and national regulations with no leaks at any fittings or valves.
- Drain water pipes/hoses are free from any restrictions (kinks) or blockages.
- The drain water does not discharge onto the roof surface.
- The water bleed rate is between 2.0 and 3.2 L/min

Record the details

Water Bleed Rate.....

WATER MANAGER KIT (only if fitted)

- The inlet water solenoid valve is installed the correct way around.
- Opening and closing the inlet water solenoid valve does not cause water hammer.
- The drain valve is installed instead of the overflow pipe.

FAN BELT

- The fan belts have been tensioned to the correct level (see next page).

Record the details

Belt Tension

Signed by Installer:

Commissioning Technician:

COMMISSIONING

FAN BELT CHECK

Important! Risk of injury to body parts coming into contact with a rotating fan. Ensure Main Isolator Switch is OFF

As components may have moved during transport, it is recommended that the fan, motor, belts and pulleys are inspected before being turned on.

- Check the fan motor is sitting level and securely fitted.
- Check that motor and fan pulleys are correctly aligned. Confirm horizontal and vertical angularity as well as axial offset are not present.



CORRECT ALIGNMENT HORIZONTAL ANGULARITY AXIAL OFFSET VERTICAL ANGULARITY

- Confirm that all pulley taper locks are secured.
- Check that the fan belt is correctly fitted and tensioned.

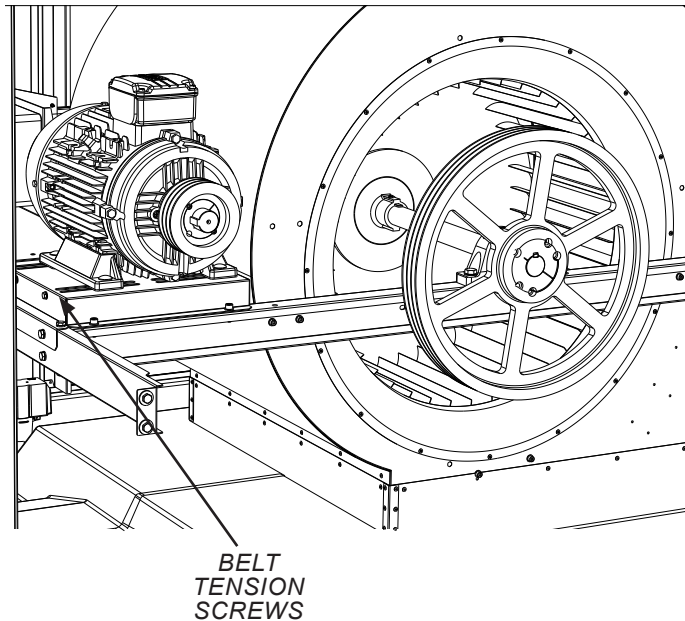

FAN RUN CHECK

Important! Risk of injury to body parts coming into contact with a rotating fan. Ensure fan is clear of all objects before starting.

- Set Main Isolator Switch to ON
- Set FAN to ON.
- Set SPEED initially to LOW speed and then HIGH speed.
- Confirm fan is spinning in the correct direction.
- Confirm no unusual or excessive sounds at both fan speeds.
- Confirm no excessive vibration and/or rattle sounds.

WATER LEVEL CHECK

Important! Risk of water being pulled into the fan and/or creating a wet roof surface. Never run the pump unless all side panels are installed.

Turn water supply on.

- Confirm water enters reservoir.
- Adjust float arm and confirm float valve shuts off when water level is approximately 10mm below overflow level.

Set COOL to ON

- Confirm pump starts.
- Confirm there are no external water leaks.
- Confirm all hose circuits are connected correctly.

COOLING PAD FLUSH & DRAIN

To reduce the probability of unusual odours, foaming, or water pull off, it is recommended to flush new cooling pads with fresh water and then drain the reservoir.

- Run the pump without the fan for 15 minutes.

After the flush process, open/remove the drain.

- Confirm the drain valve (if fitted) opens.
- Confirm water fully drains from the reservoir.

SET WATER BLEED RATE

Adjustment to the bleed rate is made by turning the bleed control tap, located externally on a corner pillar, to the desired setting.

The required bleed rate will vary with the water supply quality, but should be initially set to the recommended bleed rates as set out in below.

MODEL	LITRES PER 10 MINUTES	LITRES PER 60 MINUTES
RPXL16000	7.0	42
RPXL18000	7.4	44

If the water supply is of poor quality, higher bleed rates are necessary to ensure reasonable pad life and cooler performance.

Check the bleed rate by running into a graduated container for a set time.

Note! The water bleed is not required if the Water Manager Kit is installed.

COMMISSIONING

COOLING PAD SATURATION CHECKS

Water flow to the cooling pads is controlled by the restrictor tap located next the pump.

Pre-set the tap to ½ open and run the cooler for at least 10 minutes in COOL mode at full speed with all cooling pads fitted.

- If the cooling pads are found to have dry sections, stop the unit, and open the flow tap a small amount and re-test.
- If the cooling pads are found to be very wet, and in danger of flooding, stop the unit, and then close the flow tap a small amount and re-test.

After adjustments have been made confirm:

- All cooling pads have even water saturation.

Note! Cooling pad evaporation rates change with entering air (ambient) conditions. The water flow rate should be set with this in mind and may have to be readjusted due to seasonal weather changes.

Note! New cooling pads may require a period of conditioning to saturate correctly (approximately 3 weeks continuous operation depending on water quality).

CUSTOMER HANDOVER CHECKLIST

Run the cooler for at least 20 minutes in COOL mode at full speed and confirm:

- Leaving temperatures are sufficiently cooler than ambient temperatures.
- No unusual odours.
- No visible water leaks.
- No excess water is draining from overflow.

Explain to the customer:

- The principles of ducted evaporative cooling.
- How far the windows need to be opened.
- How to turn the cooler on.
- How to operate the wall controller.
- How to drain the cooler.

Finally, confirm that:

- The customer has been given a copy of the cooler manual which includes Operation, Maintenance & Warranty details.
- All installation rubbish has been removed.
- Any property damage reported and/or repaired.

Signed by Installer:

Commissioning Technician:

TROUBLESHOOTING

PROBLEM	POSSIBLE CAUSE	SUGGESTED REMEDY
Cooler fails to start/ not running.	No power to cooler.	Check circuit breaker. Consult with building manager.
	Switch plate wired incorrectly..	Check switch plate Fan ON/OFF wiring schematic.
	Broken belt.	Replace and tighten to correct tension.
	Failed motor.	Replace
Inadequate cooling.	Cooler running in vent mode.	Turn to cool mode.
	Fan running backwards	Rewire motor for correct rotation.
	Water inlet solenoid is installed incorrectly	Check installed in the correct water flow direction.
	Clogged or dirty cooling pads	Clean or replace cooling .
	Water pump failure.	Check pump is operating. Check switch plate Cool ON/OFF wiring schematic.
	Pumps run but insufficient water in reservoir.	Check cooler is level. Adjust float level Check water supply pressure.
	Pumps run but no water circulation to cooling	Clean pump strainer. Check water distribution system for possible obstruction in hoses. Check for blockages in the spreaders feeding the cooling .
	Inadequate exhaust from building.	Make sure there is adequate provision for exhausting air from building (open windows and doors).
	Under-sized ducts.	Carry out cooling load design to determine correct size unit, ducting and outlets required. Discuss with building manager.
	Under-sized cooler.	
	High ambient humidity.	On days during summer when ambient humidity is high the cooler will not reduce the temperature as much as on drier days. There is no remedy.
Excessive humidity.	Inadequate exhaust from building.	Make sure there is adequate provision for exhausting air from building (open windows and doors).
Noisy cooler.	Fans out of balance due to dirt, etc.	Clean the fans.
	Air duct noise	Increase size of ducts. Increase size of room registers/grilles
	Loose or slipping belts	Replace and tighten to correct tension.
Unpleasant odour.	New cooling pads.	See Commissioning Section for Pad Flush
	Cooler located near source of unpleasant odour.	Remove source of odour or relocate cooler.
	Algae in reservoir water.	Drain reservoir, clean thoroughly with strong cleansing agent, refill.
	Cooling pads remain wet after shutdown.	Run cooler on VENT mode to dry cooling out.
External water leaks.	Loose water hose connections.	Check and tighten connections.
	Blocked or undersized drains.	Check and clean drain lines.
	Float valve adjustment not correct.	Adjust float valve.
	Excessive amounts of water from drain hose.	Check drain valve seal. Check cooler is level. Adjust float level
Water carryover in supply airstream.	Clogged or dirty cooling pads.	Clean or replace cooling pads.
	New cooling pads.	See Commissioning section for Pad Flush
	Cooling pads not fitted correctly into pad frames.	Check for airgaps around water spreaders.

MAINTENANCE SCHEDULE

MAINTENANCE FREQUENCY

Maintenance of an evaporative cooler is essential in maintaining proper performance and reliability.

All maintenance must be done by competent, qualified, licensed technicians, in accordance with National and/or Local Regulations.

The frequency of service is largely dependent on the conditions under which the cooler is operated. External factors, such as air and water quality, can affect the serviceable life of the cooler and its components. In particular, installations using hard water, usually defined as greater than 200mg/L, will experience greater scaling problems requiring a more frequent cleaning regime.

Similarly, the amount and type of use can also have a significant impact. The guidelines listed below are intended to provide help in formulating a proper service regime. Local, and in some cases, individual factors should be taken into account when deciding on the frequency of visits.

HEALTH REGULATIONS. In some regions, regulations require that evaporative air coolers be serviced at specific intervals. Ensure all maintenance is done in accordance with any local and national regulations.

TYPE OF INSTALLATION	MAINTENANCE SCHEDULE SERVICING FREQUENCY
COMMERCIAL / INDUSTRIAL INSTALLATIONS (Seasonal use)	Maintenance Schedule servicing must be a minimum of twice a year, typically immediately before and after the summer season.
COMMERCIAL / INDUSTRIAL INSTALLATIONS (All year use)	Maintenance Schedule servicing must be performed every 3 months.

While installation is not covered by warranty (e.g. duct work, roof penetrations, electrical and water connections etc.), these items should be checked as they can affect the performance (and/or safety) of the cooler. For this reason, they are included in the Maintenance Schedule.

WINTER OPERATION AND SHUTDOWN

Evaporative coolers cannot be used in cooling mode in freezing conditions. In particular the inlet water solenoid valve, pumps, and drain valve are likely to fail in such conditions.

It is recommended that, to prevent damage to cooler components, the following tasks are completed before the start of the winter season.

1. Drain down and isolate the water supply.
2. Drain and clean the reservoir.
3. Remove the bleed funnel and o-ring or, if fitted, set the drain valve to the open position.
4. Isolate the power.

For installations requiring continuous operation through the winter, it is possible to run the cooler in VENT mode, however customers must ensure the controls are not accidentally set to any cooling mode in these conditions.

MAINTENANCE SAFETY

Always liaise with the Building Manager prior to starting a service.

WARNING 3 phase voltage. Always isolate and lock out the cooler power supply before performing any electrical repair or maintenance work. When the electrical isolator cannot be locked, securely fasten a prominent warning device, such as a tag, to the switch plate controls.

WARNING Risk of injury to body parts coming into contact with a moving belt. Ensure belts and pulleys are clear of all objects before starting.

WARNING Risk of injury to body parts coming into contact with a rotating fan. Ensure fan is clear of all objects before starting.

WARNING Risk of water being pulled into the fan and/or creating a wet roof surface. Never run the pump unless all side panels are installed.

MAINTENANCE SCHEDULE

MAINTENANCE CHECKLIST

DEFINITIONS

Clean - To wash and remove all dirt, grit or debris.

Check/Inspect - To visually inspect the item for correct operation, fitment and functionality.

Test - To turn the item on and off and confirm correct function.

Replace - To remove the existing item and replace with a specified genuine replacement part.

Note! It is important that only new Seeley International factory authorised replacement parts be used in this cooler. Failure to do so may void warranty, cause improper cooler performance, and unsafe operation.

SERVICE NO.	1	2	3	4	5	6	7	8	9	10	11	12
EXTERNAL INSPECTION												
Check/Inspect the following parts for general deterioration, leaks, damage, corrosion, missing components, secure connections, and function.												
Cooler Body												
Supply Air Duct												
Support Frames / Curb												
Vibration Isolation												
Roof Flashing												
Isolation Switch												
Circuit Breakers/Fuses												
Power Cables												
Control Cables												
Water Supply Pipe / Hose												
Water Supply Strainer / Filter												
Water Isolation Valve												
Drain Pipe / Hose												

INTERNAL WATER DISTRIBUTION												
Check/Inspect the following for general condition, damage and secure connections.												
Water Distribution Hoses												
Float Valve												
Clean the following components												
Pump Strainers												
Water Spreaders												
Water Probe Pins*												
Reservoir Surfaces												
Cooling Pads												
Test the following												
Water Probe Resistance*												
Correct Internal Water Levels												

*only if Water Manager Kit is installed.

FAN & MOTOR												
Check/Inspect the following for general condition, damage and correct alignment.												
Fan Blades												
Bearings & Pillow Block												
Pulleys & Taperlocks												
Motor Mounts												
Fan Belt Condition												
Fan & Motor Spins Freely												
Test the following												
Belt Tension												
Bearing Lubrication												

MAINTENANCE SCHEDULE

SERVICE NO.	1	2	3	4	5	6	7	8	9	10	11	12
FUNCTIONAL TEST												
Test the following components from the Switch Plate Control												
Inlet Solenoid Valve*												
Drain Valve*												
Pump												
Fan 2-Speed Control												
Check/Inspect the following whilst running at full speed.												
No Excessive Noise												
No Excessive Vibration												
No Water Leaks												
Cooling Pad Saturation.												
Airflow through all duct outlets												

*only if Water Manager Kit is installed.

MAINTENANCE INSTRUCTIONS

INSPECTION PROCEDURES

1. Isolate and lockout the power supply to the cooler.
2. Turn off the water supply.
3. Inspect the entirety of the cooler external body and components for general deterioration, leaks, damage, corrosion, and loose or missing fasteners.
4. Remove the side panels from all sides of the cooler.
5. Drain the cooler reservoir by removing the drain.
6. Clean the Pump Strainer & Impeller.
7. Clean the Water Probe (if fitted)
8. Clean the Water Reservoir.
9. Inspect and clean the Cooling Pads.
10. Inspect the fan, bearings and pulleys for general condition, damage and correct alignment.
11. Measure the fan belt tension and adjust as required.
12. Lubricate the fan bearings.
13. Re-fit the side panels from all sides of the cooler.
14. Turn on the power and water supply.
15. Complete the maintenance checklist and the cooler commissioning sequence.

PUMP

Disconnect the plumbing hose from the spigot at the pump base and remove the pump assembly from the cooler cabinet.

Inspect and clean the pump strainer and impeller housing. Remove any solids or residues from the strainer slots or around the impeller with a soft brush.

Note! When removing or unplugging pumps, take care to ensure they are replaced correctly.

- The pump body must be seated flush in outlet housing otherwise it will not pump sufficient water.
- Check the integrity of the hoses and their connection to the pump spigots.

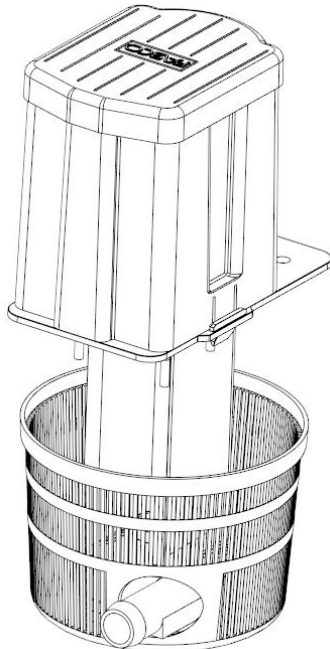

WATER PROBE

1. Unclip the probe from its bracket.
2. Clean the pins by wiping the contact surfaces with a soft cloth - DO NOT use abrasives.
3. Using a multi-meter, measure the pin resistances in the configuration below.

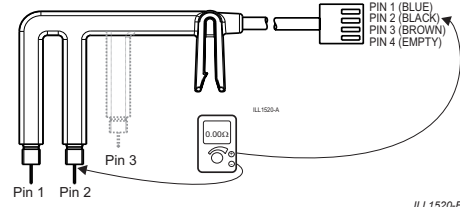

Resistance should be 0-5 ohms. A reading of 5 ohms or greater indicates a faulty probe. Check for shorts between pins: There should be an open circuit.

Note. The brown wire (Pin 3) is not connected on 2 pin probes.

WATER RESERVOIR (TANK)

Flushing of the water reservoir is best achieved with the overflow pipe / drain valve, pump, and water probe removed.

Use a water hose or low-pressure cleaner to flush all debris down the reservoir drain. After flushing wipe the bottom of the reservoir thoroughly using a wet cloth or brush.

COOLING PADS

As cooling pads age they can accumulate dirt and deposits which may reduce the water flow rate they can handle without producing water carryover.

Blocked pads may have to be replaced if the blockage cannot be cleaned out. Alternatively, the water or airflow may need to be temporarily reduced to compensate. This will result in reduced cooling capacity.

Visually inspect the flutes of the cooling pads for signs of deterioration or restriction.

Inspect pad-retaining components (pins, clips, wire mesh etc) for damage or corrosion and ensure they are correctly and securely fitted.

Cooling pads may be gently hosed to remove loose material, however they are fragile and care must be taken when handling or hosing to prevent damage.

Note! Do not wash the cooling pads with high pressure water spray. If the cooling pads are salted-up, replace them.

FAN BELT

Check the condition of the fan belt. Look for cracks, splits and tears.

Measure the belt tension. If found to be outside the specification shown in the Commissioning section of this manual, use the adjustment bolt to move the move platform.

Belts which are unable to reach the minimum tension have stretched and should be replaced.

PULLEYS & TAPERLOCKS

Check the condition of both pulleys. Look for signs of corrosion, wear, cracks, and chips. Make sure pulleys and taperlocks are firmly attached to shafts. Worn pulleys will shorten belt life and can cause belt slipping and puts strain on bearings.

BEARING LUBRICATION

Check the bearing housings for signs of corrosion, wear, and correct alignment. Spin the fan by hand and listen for grinding, scraping or knocking sounds. Check there is no lateral (up & down) movement on the fan shaft.

Note! Bearings should be relubricated each service with general purpose bearing grease. When relubricating, turn the shaft by hand and pump the grease until fresh grease starts to escape from the seals. Excessive pressure from pumping too quickly can damage the seals.

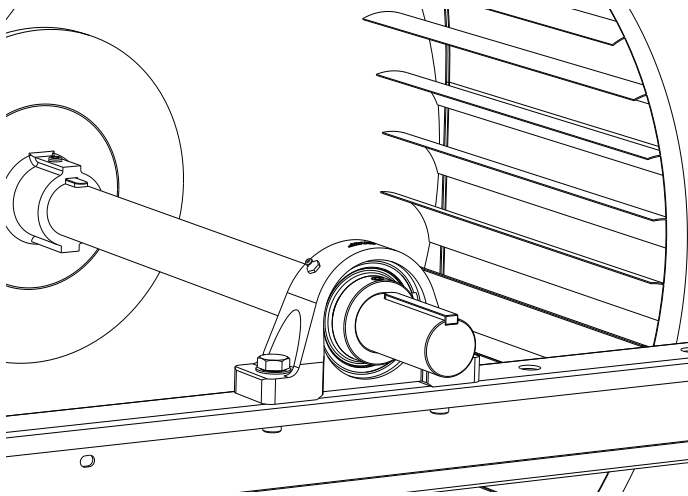

WARRANTY TERMS (AUSTRALIA AND NEW ZEALAND)

HOW TO REGISTER YOUR PRODUCT WARRANTY (Australia and New Zealand only)

Please register your warranty online by visiting seeleyinternational.com

Step 1 - select “**Service**” then “**Product Warranty Registration**”

Step 2 - Enter your product serial number and “**Submit**”

Step 3 - Enter the required information and “**Submit**”

Important Note: You need to have the following information to complete your registration:

- your unit model and size
- serial number
- date your system was installed
- name of the dealer you purchased it from

Please complete this section. You will also need to retain your purchase receipt, and proof of any warranty period extension.

Brand: _____

Model: _____

Serial No: _____

Customer Name: _____

Installation Address: _____

Installation Type: Residential / Non Residential / Commercial

Date of installation: _____

Installer / Dealer: _____

As with any product that has moving parts or is subject to wear and tear, it is **VERY IMPORTANT** that you maintain your Cooler / Heater and have it regularly serviced. It is a condition of warranty cover for your Cooler / Heater that you comply with all of the maintenance and service requirements set out in the Owner’s / Operation / Service Manual. Compliance with these requirements will prolong the life of your Cooler / Heater. Further, it is also a condition of warranty cover that each item in the Maintenance Schedule in the Owner’s / Operation / Service Manual is performed with the frequency indicated, by a qualified, licensed technician, and that the Maintenance Schedule is properly filled out (i.e. names, signature, date, and action taken) when the item is completed.

ANY FAILURE TO CARRY OUT THE REQUIRED MAINTENANCE AND SERVICING REQUIREMENTS, AND ANY FAILURE TO PROPERLY FILL OUT THE MAINTENANCE SCHEDULE, WILL VOID YOUR WARRANTY.

WARRANTY TERMS (AUSTRALIA AND NEW ZEALAND)

In this warranty:

We or **us** means Seeley International Pty Ltd (Seeley) ABN 23 054 687 035, and our contact details are set out at the end of this warranty;

You means you, the original end-user purchaser of the Goods;

Supplier means the authorised distributor or retailer of the Goods that sold you the Goods in Australia or New Zealand;

Goods means the product, unit, appliance or equipment which was accompanied by this warranty and purchased in Australia for installation and use only in Australia, or purchased in New Zealand for installation and use only in New Zealand; and

Relevant Warranty Period means the various warranty periods as described in clause 1 and clause 3 below, as appropriate.

For Australian customers: Our Goods come with guarantees that cannot be excluded under the Australian Consumer Law. You are entitled to a replacement or refund for a major failure and for compensation for any other reasonably foreseeable loss or damage. You are also entitled to have the Goods repaired or replaced if the Goods fail to be of acceptable quality and the failure does not amount to a major failure.

In addition to any rights and remedies that You may have under the Australian Consumer Law, the Customer Guarantee Act 1993 (New Zealand) or any other law, subject to the terms of this warranty, We provide the following warranty:

1. If during the first one (1) years from the date of purchase, the Goods upon examination prove defective by reason of improper workmanship or material, We will repair or replace, at our option, the Goods or any part thereof without charge for either parts or labour, during normal working hours.
2. The warranty granted under clause 1 applies to all components which form part of the original cooler / heater, but does not cover:
 - a) fair or normal wear and tear;
 - b) damage, loss or claims caused by, resulting from, or arising out of any utilities that service or are connected to the Goods. This includes but it is not limited to electrical surges, and inadequacies, failure, or other problems in or with any electricity, power, or water supply to the Goods;
 - c) after the first year: (i) the replacement, supply, or servicing of consumable items (including without limitation cooler pads, washers, seals, drive belts) and (ii) maintenance adjustments to the cooler / heater; and
 - d) despite clause 2.c. above, air filters;
 - e) installation (including without limitation ductwork, fittings, and other related installation components) which is excluded.
 - f) batteries (including damage caused by leaking or faulty batteries), cracking or breaking of display screens in controllers, physical damage caused by the user or third parties, and accidental breakage.
3. Seeley also warrants the Fan Motor for the first two (2) years from the date of the Goods purchase, if upon examination prove defective by reason of improper workmanship or material, We will repair or replace at our option, the Fan Motor or any part thereof without charge for parts, during normal working hours.
4. During the period to which any expressed warranty applies, all defective part(s) shall be replaced or repaired (at the discretion of Seeley) without charge for either parts or labour, during normal working hours. Should we deem in our absolute discretion to replace the Goods pursuant to clause 1 or clause 3, we may substitute any similar good even if it is not on our current price/equipment list. Further, Goods presented for repair may be replaced by refurbished goods of the same type rather than being repaired. Refurbished parts may be used to repair the Goods.
5. We are under no obligation to repair or replace the Goods or Parts under clause 1 and 3 above if (i) the Goods have not been installed and commissioned in accordance with the Installation Manual (ii) the Goods have not been installed and commissioned properly or competently, (iii) the Goods have not been operated, serviced and maintained in accordance with the instructions provided in the Owner's Manual, or (iv) if any such service or maintenance has not been properly or competently performed. It is a condition of warranty cover that each item in the Maintenance Schedule in the Owner's / Operation / Service Manual (if it was published with such a Schedule) is performed with the frequency indicated, by a qualified, licensed technician, and that the Maintenance Schedule is properly filled out (ie names, signature, date, and action taken) when the item is completed. Any failure to carry out the required maintenance and servicing requirements, and any failure to properly fill out a Maintenance Schedule in the Manual, will void your warranty. The addition of any third party device, (except where it is required by the installation instructions and complies with those instructions), or the removal or alteration of any Seeley component, or damage due to misuse of the unit, or faulty installation or commissioning, will void this warranty.
6. As far as the law permits, We will not be liable for any consequential loss suffered through, or resulting from, the non-operation, or ineffective operation of the cooler / heater. The warranties granted under clause 1 and clause 3 do not cover damage to the cooler / heater or other loss resulting from acts of God.
7. No other person, company or corporation is authorised to offer, or give on our behalf, any other warranty. The benefits conferred are in favour of You and any person deriving title to the cooler / heater whilst in its original place of installation. Nothing in this warranty shall be construed as affecting any rights You may have under all the relevant laws, or Commonwealth or State Legislation which give You rights which cannot be modified or excluded by agreement.
8. In order to claim under the warranties granted under clause 1 or clause 3 You must:
 - a) either:
 - contact us within the Relevant Warranty Period on Australia 1300 650 644, New Zealand 0800 589 151; or
 - log a warranty claim on our website (website address below) within the Relevant Warranty Period; and
 - b) make available for inspection by the service agent who will come to the location of the Goods or send to us at the address below within the Relevant Warranty Period: (i) the legible and unmodified original proof of purchase, which clearly indicates the name and address of the original retailer, the date and place of purchase, the product name or other product serial number, (ii) all of your records of all service and maintenance carried out to the Goods, plus the Maintenance Schedule in the Owner's Manual (if it was published with such a Schedule), (iii) a copy of the completed Warranty Information section above, and (iv) if an extended warranty period was provided by Seeley International for the Goods, then the relevant document provided by Seeley International confirming that extended warranty period. If you choose to send the documents described in (i) to (iv) to Seeley International, then they must be accompanied by a covering letter which states your name and address and daytime telephone number, the address at which the Goods are installed, and the model and serial number of the Goods.

WARRANTY TERMS (AUSTRALIA AND NEW ZEALAND)

9. The warranty granted in clause 1 and clause 3 covers the costs of parts and labour but you will be responsible for:
 - a) the cost of travel incurred for a Seeley International service agent to get to and from the location of the Goods if the location of the Goods is either: (i) outside the metropolitan areas of the capital cities; or (ii) more than 35 kilometres from an authorised Seeley International branch or service representative; and
 - b) any costs for additional labour or equipment associated with gaining acceptable and safe service access to the Goods installed in restricted, high or unsafe locations, and/ or the removal and replacement of any barrier, walls, roofs, fences etc; and
 - c) any costs incurred by the Seeley International service agent in gaining access to the Goods which is necessary to comply with any safety or workplace safety requirements and/or any other relevant regulations. For the avoidance of doubt, the reference to any costs incurred also includes the cost of any necessary site inductions.
10. We are not responsible in any way for any failure and/or inadequate performance of the Goods which arises from or is connected to the use in the Goods of non-genuine spare parts. Seeley International strongly recommends that only spare parts supplied or approved by it are used in the Goods.
11. The employees and Executive of Seeley International are not responsible for the installation of the Goods and expressly disclaim all liability resulting from incorrect installations or installations that do not conform to local electrical codes, local plumbing codes, Occupational Health and Safety requirements, and by laws which are legislated or in effect at the time of installation.
12. This warranty is only valid and enforceable in Australia and New Zealand. (For New Zealand, this warranty only applies to goods that We supply specifically for distribution and sale in New Zealand.)

Note: It is important that the safety and privacy of our service technicians is protected at all times. Accordingly, We and our Seeley International service agents reserve the right to refuse service if (i) safety and accessibility to the unit cannot be guaranteed or (ii) the owner of the unit, occupant of the site where the Goods are located, or any other third party seeks to take photographs, or make a video or audio recording, of the service technician(s) while they are on the site or carrying out service to the unit. If a service technician attends the site but subsequently leaves for any of these reasons then a service charge will be made for the call which charge shall be a debt immediately due and payable by the person or entity that has made the claim under this Warranty. If a service call reveals no warranty fault found with the Goods, a charge will be made for the call.

Our liability under this warranty is limited to the extent permitted by law. That is, to the extent that it is fair and reasonable, if the Goods are not of a kind ordinarily acquired for personal, domestic or household use or consumption, your remedies associated with any failure or defect of the Product will be limited to:

- a) the replacement of the Goods or the supply of equivalent goods;
- b) the repair of the Goods;
- c) the payment of the cost of replacing the Goods or of acquiring equivalent goods; or
- d) the payment of the cost of having the Goods repaired

and subject to the terms and conditions included in this warranty.

SERVICE DEPARTMENT

Seeley International Pty Ltd
112 O'Sullivan Beach Road
Lonsdale, South Australia 5160
Customer Service Centre 08 8328 3844
Website: www.seeleyinternational.com

FOR SERVICE

To book a Service on your Seeley International product:

Visit www.seeleyinternational.com then select “**Service**” and “**Find a Service Agent / Request a Service**” then enter the required information.

or Phone Australia 1300 650 644 or New Zealand 0800 589 151 to be directed to your closest authorised Service Agent.

PRIVACY NOTICE

Seeley International Pty Ltd ABN 23 054 687 035 will use the personal information you provide us with to provide warranty support for the product you have purchased and to inform you about other products and services. If you choose not to supply us with the information requested, we may be unable to provide you with warranty support. We may also disclose your information to third parties, such as related entities; retailers, distributors, service agents and contractors who are affiliated with us; or marketing or market research companies. If you would prefer not to receive direct marketing communications from us, please follow the instructions to “unsubscribe” which will be included in the direct marketing communications we send you, or contact our Privacy Officer using the details set out below. While we do not currently transfer personal information to recipients who are outside of Australia or New Zealand or store personal information outside of Australia, if we transfer your information to third parties who do so, we will take reasonable steps to ensure that the overseas recipients do not breach the Australian Privacy Principles or if you are a New Zealand customer, the New Zealand Privacy Principles. By registering your warranty, you consent to having your personal information used in this way. Please read our Privacy Policy on our website www.seeleyinternational.com for further explanation of how we collect, use, hold and disclose personal information, and how you may access and seek correction of your information. It also sets out how you may complain about a breach of the Australian Privacy Principles, or if you are a New Zealand customer, a breach of the New Zealand Privacy Principles, and how we will deal with your complaint. You may contact us at: Privacy Officer, Seeley International Pty Ltd, 112 O'Sullivan Beach Road, Lonsdale, South Australia 5160.

APPENDIX A

3 PHASE WIRING DIAGRAM

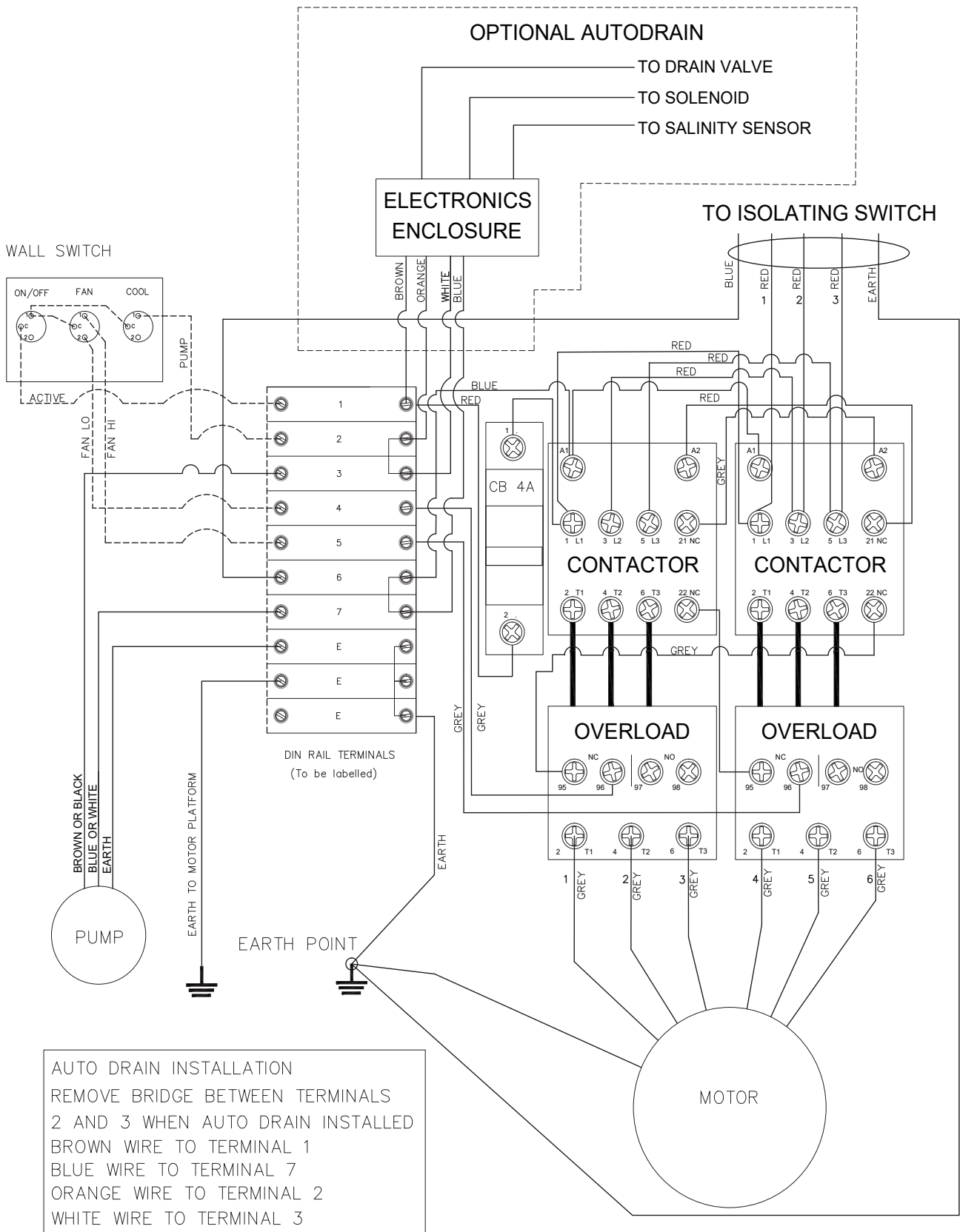

Affix serial & model
number sticker here



Warranty Service

Australia: 1300 650 644

New Zealand: 0800 589 151

Seeley International Technical Support

Australia: 1300 650 399

New Zealand: 0800 589 152

For all other regions, contact your local distributor:

seeleyinternational.com

Online Support Portal (AUS/NZ)

Scan or Click QR Code



It is the policy of Seeley International to introduce continuous product improvement.

Accordingly, specifications are subject to change without notice.

Please consult with your dealer to confirm the specifications of the model selected.