

Installation, Operation & Service Instructions

Braemar

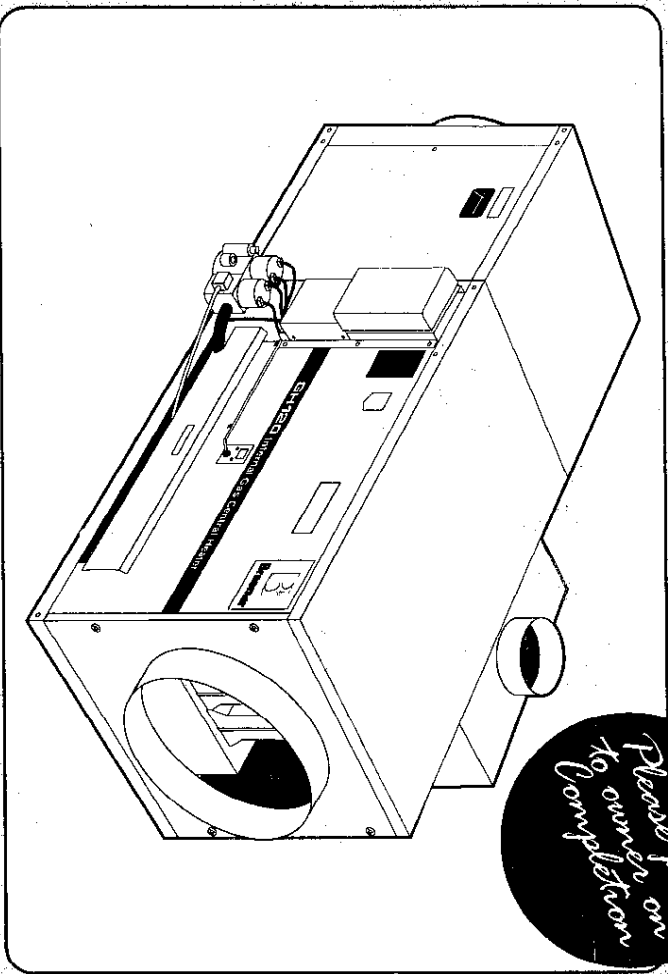

Internal Gas Control Heaters

Models

GH35 GH90 GH120



IMPORTANT

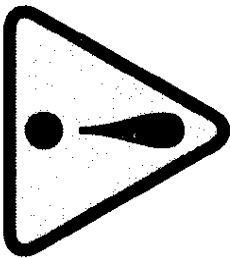

DO NOT Operate this appliance before reading the instruction booklet.

DO NOT Place articles on or against this appliance.

DO NOT Store chemicals, flammable materials or spray aerosols near this appliance.

DO NOT Operate with panels, covers or guards removed from this appliance.

FOR INSTALLATION INDOORS ONLY.

TO BE INSTALLED BY AN AUTHORISED PERSON ONLY.

THIS APPLIANCE MUST BE INSTALLED ON A

NON-COMBUSTIBLE BASE.

GH030

Introduction

CONGRATULATIONS on choosing a Braemar Central Heating Unit. Your Braemar Heater is built from the highest quality materials and is engineered to provide many years of trouble free performance. Please take a moment to read these instructions and keep them for future reference.

General

The furnace should be installed in accordance with these instructions, local gas fitting regulations, municipal building codes, electrical wiring regulations, Australian Gas Association Installation Code for gas-burning appliances and equipment and any other relevant statutory regulations.

Delivery

The customer or installer, upon delivery of the unit, should ensure that the model number of the heater is as requested and designed for the gas which it is intended to be connected to. A data plate is located on the side panel, and it gives both model and gas type. Please check the heater for freight damage.

Location and Clearances

Your GH Series Heater is designed for indoor installation only and should be located either in the ceiling space or under the floor.

The following list is a guideline for safe installation of the heater and should be read in conjunction with the Installation Code, AG601.

This appliance is not suitable for installation on the downstream side of an Evaporative Cooler. This appliance is not suitable for installation in a marine environment.

Installation Instructions

*Note: This heater is to be installed only by an authorised tradesperson.

Ceiling Installation

1. Inspect the roof space and check that it is strong enough to support the extra load. The heater should be mounted over a wall so that it is not being supported by the ceiling joists alone.
2. A service platform should be provided adjacent to the heater (chipboard or similar). A permanent walkway to the ceiling access point should be provided.
3. The heater can be mounted on a permanent platform (19mm particle board or equivalent) covered with a fire resistant base at least equal in fire resistance to 6mm millboard. A 25mm air gap is provided between the base of the heater and the non combustible base to provide air circulation under the heater. The heater can also be mounted on a permanent platform covered with corrosion resistant sheet metal (0.6mm thick). An air gap of 100mm is required using metallic or concrete spacers. Alternatively the heater may where practical be suspended on threaded rods to provide a 100mm air space underneath the heater. The platform and corrosion resistant base must extend to the full perimeter of the heater and 300mm beyond the front and rear of the heater.
4. Permanent artificial lighting should be provided to assist servicing of the heater. The switch for the light should be at the ceiling access point.
5. **REMOVAL OF THE BURNER TRAY.** The burner tray on all units is removable as a complete unit. A minimum clearance of 600mm should be provided for easy removal.
6. **REMOVAL OF THE FAN.** The fan is removable through the service doors on the side of the heater. To remove the fan a minimum clearance of 500mm is required.

Under floor installations

When installing the Braemar Heater under the floor, it is important that all aspects of safety are considered and that provision is made for easy service of the heater.

1. The **MINIMUM CLEARANCE** required to locate an appliance is 850mm between the underside of the floor joists and the ground level. At all times a clearance of at least 200mm should be provided between the underside of the floor joists and any portion of the appliance or its components to allow for minimum flue rise.
2. Where the **CLEARANCE** between the underside of the floor joists and ground level is 1.2m or less, then the heater should be installed within 2m of the access door to provide easy access.

3. Where CLEARANCE between the underside of the floor and ground level exceeds 1.2m, the heater may be installed at any distance from the access door.
4. The heater should be mounted on a level 50mm thick concrete base over the whole area of the base of the appliance and provision made to drain any seepage or ground water away so that water cannot come into contact with the heater.
5. Artificial lighting should be provided to assist servicing. The switch for the service light should be at the access door.
6. REMOVAL OF THE BURNER TRAY. The burner tray on all units is removable as a complete unit. A minimum clearance of 600mm should be provided for easy removal.
7. REMOVAL OF THE FAN. The fan is removable through the service doors on the side of the heater. To remove the fan a minimum clearance of 500mm is required.
8. LATERAL FLUES from appliances shall not exceed 2m in length with a minimum rise of 20mm per metre run. If the location does not permit this, provision should be made for a duct to carry the flow vertically off the heater through the building to terminate in open atmosphere.

Fueling the heater

The heater must be fueled in open atmosphere. The flue should be terminated with an approved Australian Gas Association anti downdraught gas cowl.

Fitting the Draught Diverter

Before connection of the flue, the stainless steel draught diverter provided should be fixed to the flue outlet. Eight screws are provided and no drilling is required for this operation. Ensure ALL screws are fitted and tight.

NOTE: The flue should NOT be supported by the draught diverter. The flue spigot on the draught diverter is designed to fit inside the flue.

FLUE SIZES	125 MM DIAMETER
GH-65	"
GH-90	"
GH-120	"

Electrical Connection

Your Braemar central heating unit comes pre-wired to a three pin plug, to plug into a standard 10 amp power outlet.

Thermostat Location

The room thermostat should be located approximately 1.5 metres above floor level. Avoid placing the thermostat in draughty areas, or where hot spots could occur due to radiation from sun rays, television sets, refrigerators or warm air ducts. Central hallways generally have no windows and retain heat longer than surrounding rooms, which could mean that the thermostat does not sense the true temperature of the living area. Consideration should be given to all factors before deciding on the location.

Thermostat Wiring

The Thermostat wiring is 24 volt A.C. Before connecting the thermostat wires to the heater, the testing loop wire MUST be removed. Failure to do so will cause damage to the heating anticipator in the thermostat. Connection of the thermostat wires does not require removal of the electrical box cover panel.

Gas Connection

Your Braemar Heater is provided with a 20mm diameter compression fitting for attachment to the gas line. A gas cock should always be provided adjacent to the heater for servicing. Before connecting the gas to the heater the gas line should be carefully purged to remove air from the line.

Braemar Warm Air Gas Furnace GH Series - Internal Horizontal

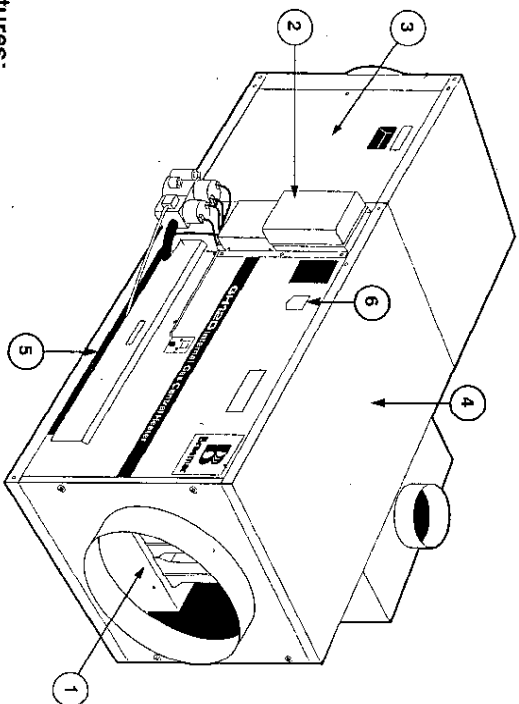

Features:

1. Heat exchanger - 10 year warranty
2. Fully automatic electronic ignition
3. Reversible fan housing (right or left hand discharge)
4. Insulated cabinet
5. Stainless steel burner - 10 year warranty
6. Approved by Australian Gas Association
7. Multiple speed fan - suitable for add-on air conditioning
8. Designed and manufactured in Australia to exacting standards

Specifications

Model No.	GH65	GH90	GH120	GH65 EZE High	GH90 EZE High	GH120 EZE High
Heat Input (MJ)	65	90	120	65	90	120
Heat Output (Kw)	14	20	27	14	20	27
Air Flow (L/s@ 125Pa)	330/380	430/495	480/710	380	250	495
Flue Size (mm)	125	125	125	125	125	125
Duct Connections(mm)	300	350	400	300	300	350
Blower Motor (Watts)	315	315	600	315	315	600
Electrical Specification	240Volts 50Hz 1 Phase 3 Pin Plug (LHS)					
Gas Inlet	20mm(3/4 inch) BSP Compression Nut(LHS)					
Furnace Weight (Kg)	62	69	82	62	69	82

Ductwork Connection

Starter spigots are provided with the heater to allow for direct connection of flexible duct. Please ensure that service doors are not obstructed by the ductwork. Please follow the guidelines below:

- 1. OUTLET REGISTERS**
An outlet register must be provided in all areas to be heated. It is recommended that a register be provided for every 14m² of floor space. (150mm duct). Where this is not possible larger outlets may be provided, however care should be taken to prevent cold spots being created by too much draught, or inadequate outlets.
2. Ductwork should be adequately supported and free from air leaks.
3. Volume dampers should be provided for proper balancing of the system.
4. Ductwork should be adequately sized to prevent backpressure on the heater. Inadequate duct may cause premature failure of the fan motor, or the heat exchanger.

5. RETURN AIR DUCTING

Return air should be drawn from a suitably heated area. The return air duct should never be terminated in such a manner that it can be accidentally blocked by placing clothing, carpet or the like over it.

Where a filter is fitted to the return air grille it should be cleaned fortnightly and replaced yearly. The provision of filters in return air grilles may generate some noise. If a filter is fitted, the return air grille size must be increased by at least 30%.

SUGGESTED RETURN AIR

GRILLE SIZES ARE AS FOLLOWS:

GH-65	500x400	or equivalent
GH-90	600x400	or equivalent
GH-120	750x400	or equivalent

ADD-ON COOLING

A refrigerated cooling coil may be added to the system provided that the following points are observed.

- A Ductwork should be enlarged to provide for greater air flow.
- The fan should be connected to high speed.
- The coil MUST be fitted to the supply air duct.

NOTE:

Connection of the coil to the return air duct will cause condensation on the fan and the heat exchanger and may cause premature failure.

for Commissioning

PRE-START CHECK LIST

FURNACE - CHECK

- No leaks in gas lines. Do not use flame to locate leaks. Use soap solution.
- Blower correctly wired.
- Controls correctly wired and adjusted.
- Filters are clean and in place.
- Check registers and return air grille are open.
- Ductwork adequate.

THERMOSTAT - CHECK

- In suitable location.
- Correctly wired.
- Level.
- Heat anticipator on room thermostat set to 0.3 amps. (Non electronic thermostat only).

4.

Gas Pressure

1. NATURAL GAS

The gas pressure is factory set at 875 kPa (3.5" W.G.). To adjust pressure remove cover screw to expose adjusting screw. (Tightening the screw increases gas pressure). Adjustments to gas pressure should not be made unless proper measuring equipment is available.

2. L.P.G.

For all L.P.G. units the gas valve regulator is disengaged. Gas pressure should be adjusted at the regulator on the gas cylinder to 2.75 kPa (1" W.G.)

Instruct the User

To avoid service calls ensure that the dampers are open to at least the minimum number of outlets. A guide for normal domestic installations for the minimum number of outlets open at any one time is:

GH-65	- 4
GH-90	- 6
GH-120	- 8

Proper instruction should be given for lighting the furnace and for programming of electronic thermostats. Instruction should also be given on the requirement for regular service of the heater and cleaning of any filters.

Operating Instructions

SAFETY

Before operating the heater, please ensure that the following precautions are strictly adhered to.

- Do not place articles on or against the appliance.
 - Do not store flammable materials near this appliance.
 - Do not spray aerosols in the vicinity of this appliance while it is in operation.
- Your Braemar heater is fitted with fully automatic electronic ignition. This is an energy saving device and eliminates the need for lighting the pilot.

TO TURN THE HEATER ON, simply follow the instructions below.

- Set Room Thermostat to BELOW room temperature.
- Turn Gas Tap & Power ON.
- Set Room Thermostat to ABOVE room temperature.
- The unit is now in automatic mode.
The sparkler operates to light the pilot and will continue sparking for up to 45 seconds. When pilot lights, the sparkler will stop and the main burner will light. After approximately one minute the fan will come on.
- Set room temperature to the desired temperature.

NOTE: If Pilot does not light (unit has been out of use for some time at initial start up), set Room Thermostat to OFF. Wait three seconds and set Room Thermostat to above temperature. Wait for approximately one minute for fan to come on. Repeat if necessary.

Power Failure

In the event that a power failure occurs during the operating cycle, the heater will automatically shut down. When power is restored the heater will re-ignite and the fan will start immediately. Power failure during the operating cycle MAY cause the overtemperature switch to trip. In this event it will be necessary for it to be reset by an authorised service person.

If unit does not operate satisfactorily refer to trouble shooting chart in instruction manual or contact your nearest Braemar Service Agent.

Head Office & Factory: Albany (060) 411 611 Adelaide (08) 347 4488
Melbourne 1800 816 815 Sydney/A.C.T. (06) 292 1919
Perth (09) 446 9911 Moree (067) 527 247
Bendigo (054) 425 188

5.

Check the Grilles

To obtain good performance and durability from your heater, please ensure that at least the minimum number of grilles are open. Refer to "Commissioning Instructions" for details.

How to change fan speed

Fan speed is changed by re-arranging the incoming active into the terminal block mounted on circulating fan housing as follows. Change brown active wire on terminal strip to correspond with desired speed.

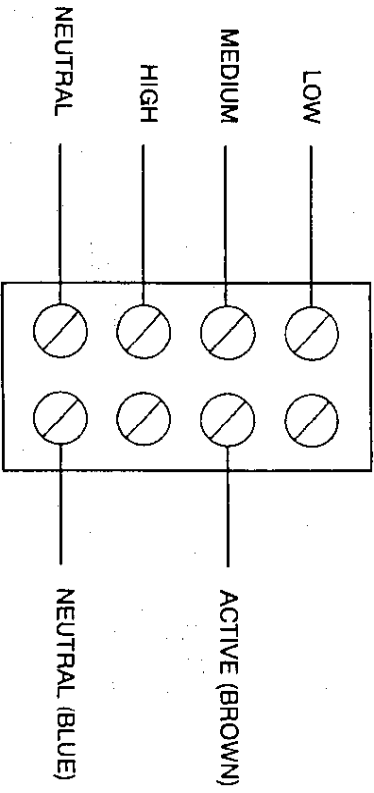

Service Instructions

*NOTE: Service work should only be carried out by an Authorised Person.

Warning

Before attempting to service the heater, turn off power and gas to unit. If the heater is running, turn off gas supply first and let the fan cool the heat exchanger, otherwise the over-temperature cutout switch might be tripped.

Blower Maintenance

The direct-driven blower is equipped with lifetime lubricated bearings and does not require oiling. Blower motor and wheel have to be cleaned out for any lint deposits. A vacuum cleaner and soft brush are best for this job.

Access to blower is by removing screws on blower door on side of unit and removing blower door.

Burners

To remove burners. Turn power off, turn gas of. All wiring on gas valve (note terminals) has to be removed. Remove gas incoming line. Undo screws holding the burner tray to the heat exchanger and pull entire burner tray out. Burners can then be checked for dust or corrosion. (Ensure correct alignment and replace all screws when replacing burner tray). Failure to accurately replace burners may cause premature failure of heat exchanger.

Braemar Warm Air Gas Furnace GH Series - Internal Horizontal Fan Performance

External Resistance 50 Pa / 0.2 inches

Model No.	GH65	GH90	GH120
Lo Speed (L/s)	400	490	560
Med Speed (L/s)	425	540	655
Hi Speed (L/s)	445	580	830

External Resistance 100 Pa / 0.4 inches

Model No.	GH65	GH90	GH120
Lo Speed (L/s)	370	450	520
Med Speed (L/s)	385	490	610
Hi Speed (L/s)	400	525	760

External Resistance 125 Pa / 0.5 inches

Model No.	GH65	GH90	GH120
Lo Speed (L/s)	330	430	490
Med Speed (L/s)	360	465	575
Hi Speed (L/s)	375	495	710

External Resistance 150 Pa / 0.6 inches

Model No.	GH65	GH90	GH120
Lo Speed (L/s)	310	400	445
Med Speed (L/s)	335	435	550
Hi Speed (L/s)	350	470	680

External Resistance 175 Pa / 0.7 inches

Model No.	GH65	GH90	GH120
Lo Speed (L/s)	275	365	405
Med Speed (L/s)	300	400	510
Hi Speed (L/s)	320	435	630

Servicing Guide

1. Check power at isolating switch.
2. Turn gas on at cocks.
3. Light burner per instructions on unit.

DEFECT	CAUSE	REMEDY
--------	-------	--------

Ignitor does not spark	Power not turned on. Thermostat set too low. Faulty ignition lead causing shorting to cabinet. Faulty ignition box Over temperature switch tripped.	Turn on Adjust Thermostat Replace Ignition lead. Replace Box Reset.
------------------------	---	---

Ignitor sparks but pilot fails to light.	Air in gas line. Gas turned off. Faulty gas valve. Incorrect wiring on gas valve Blocked pilot injector.	Purge gas line, turn Thermostat off for 3 seconds then turn thermostat back on. Turn on. Replace valve. Check wiring. Clean or replace
--	--	--

Pilot lights but main burner does not light, continues sparking.	Sparker wire not properly connected Faulty ignition pack. Gas pressure too low. Cross ignitor removed or damaged. Heater in draughty location	Check connections Replace & return for repair Adjust. Repair or replace Relocate heater.
Burner ignites explosively	Heater in draughty location	Relocate heater.

4. Check for gas leakage.		
5. Check blower operation check air quantity in return air duct against specifications.	Blower wheel loose on motor shaft. Ductwork broken. Return air blocked Ducting possibly blocked or crushed.	Tighten. Repair. Replace or clean filter. Clean or replace.

DEFECT	CAUSE	REMEDY
--------	-------	--------

Noisy blower operation.	Blower wheel rubbing on scroll.	Relocate wheel
Heater vibrates when blower starts.	Excessive duct resistance Ducting crushed. Blower wheel out of balance	Modify duct layout Repair Replace blower wheel.

6. Check condition of flame and gas.	Flame small & weak. Gas pressure in manifold too low. Supply pressure too low. Blocked line. Burners dirty & blocked. Blocked flue. Sooted Heat Exchanger. Hole in heat exchanger.	Adjust valve pressure Remove supply line & replace. Remove & repair. Clean. Remove & Clean. Replace heat exchanger
--------------------------------------	---	---

7. Check blower starts in approx 1 minute	Blower fails to start. Faulty fan relay. Loose or broken wiring Motor faulty.	Replace ignition pack return for repair. Repair Replace motor.
---	--	--

8. Turn room thermostat to less than ambient temp.	Main burner fails to cut out. Faulty room thermostat. Short circuit in wiring.	Replace
--	--	---------

9. Run unit through full operating cycle.		
---	--	--

Braemar Warm Air Gas Furnace GH Series - Internal Horizontal Wiring Diagram

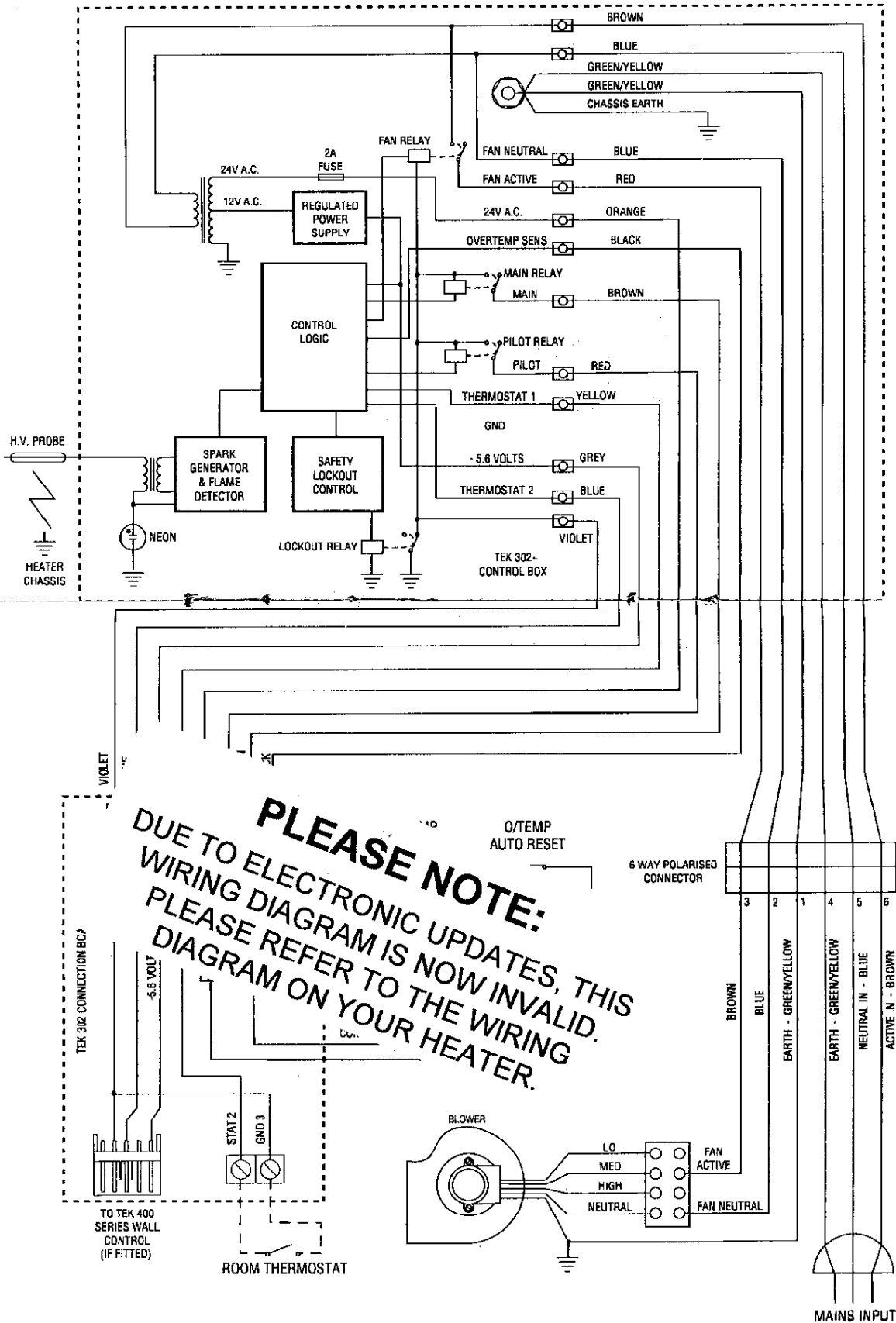

PLEASE NOTE:
DUE TO ELECTRONIC UPDATES, THIS
WIRING DIAGRAM IS NOW INVALID.
PLEASE REFER TO THE WIRING
DIAGRAM ON YOUR HEATER.

10.

11.

Braemar Warm Air Gas Furnace GH Series - Internal Horizontal Dimensions

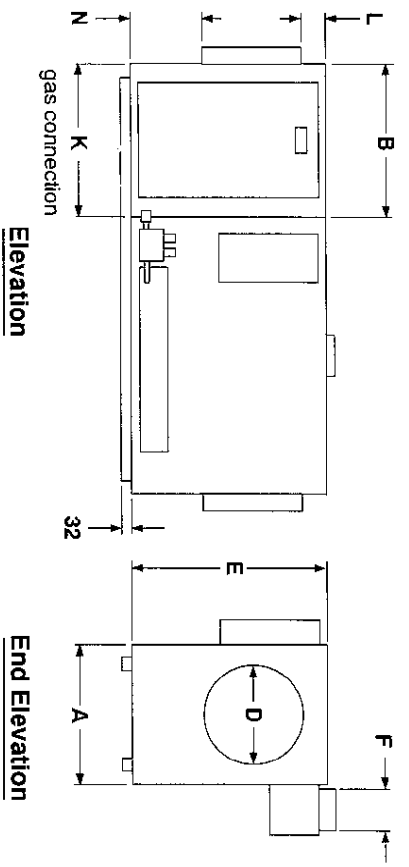
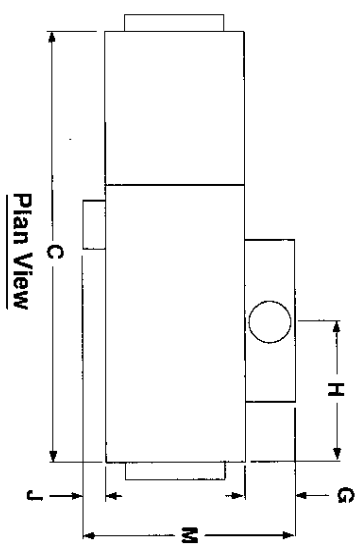

Model	A	B	C	D	E	F	G	H	J	K	L	M	N
GH65	420	460	1300	300	590	125	160	420	80	425	50	660	235
GH90	420	460	1300	350	590	125	160	420	80	425	50	660	185
GH120	500	540	1380	400	590	125	160	510	80	505	95	740	95

March 93



Braemar

Supplementary Operating Instructions

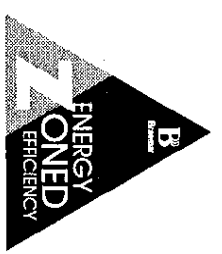

GAS CENTRAL HEATERS

MODELS

GH65EZE GH90EZE GH120EZE

Braemar EZE, How it works.

Your Braemar EZE gas central heater control system has been designed to provide you with efficient, cost effective whole of home heating. The EZE system lets you programme the temperature you require for the time you would like.

By simply selecting the "High" or "Low" setting, you could be heating your whole home, or heating only the rooms you have nominated, saving you money.

Before Using your Central Heater.

Please read the instructions on this sheet and your programmable thermostat Owners' Manual carefully. Familiarise yourself with the controls. Once you understand the purpose of each control you will be able to get the most benefit from your heater. Your installer should demonstrate the operation and procedures set out in the instructions.

Important. Only one third of the outlets should be closed off when EZE "Low" is selected. Never run the heater on "High" with outlets closed off, this will make the heater noisy and draughty, and may activate the Automatic Shutdown System should the heater over-heat.

Operating the EZE Control

The information below supersedes Page 21 of the programmable thermostat owners manual.

On the bottom left hand corner of your thermostat there is a small slide switch. This switch, marked "High" and "Low" controls all of the Energy Zoned Efficiency Functions. (fig. 1)

Switch on "High" Setting.

With the slide on the "High" setting your heater will be warming your whole home through all the outlets.

Switch on "Low" Setting.

With the slide on the "Low" setting, your heater will now be heating your home at a reduced rate. The heater fan will automatically switch down to low speed and the amount of gas burnt will reduce significantly. A damper, where fitted will be automatically switched by the EZE Control directing warm air to your designated rooms. If no damper is fitted, floor outlets should be closed off manually.

Figure 1. Braemar EZE Thermostat

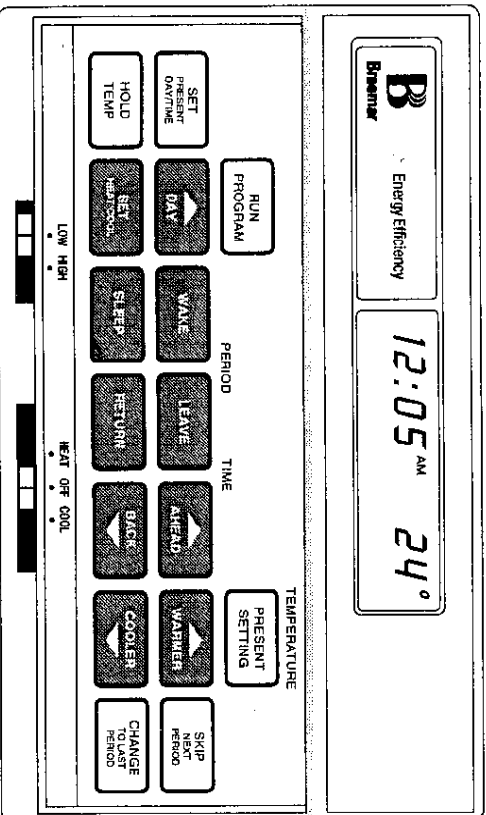

Keep all instructions in a safe place for future reference.

WIRING DIAGRAM GHEZE

FOR SERVICE PHONE

ALBURY 060 411 611

MELBOURNE 1 800 816 815

PERTH 09 446 9911

ADELAIDE 08 347 4488

ACT/SYDNEY 06 292 1919

MOREE 067 527 247

BENDIGO 054 425 188

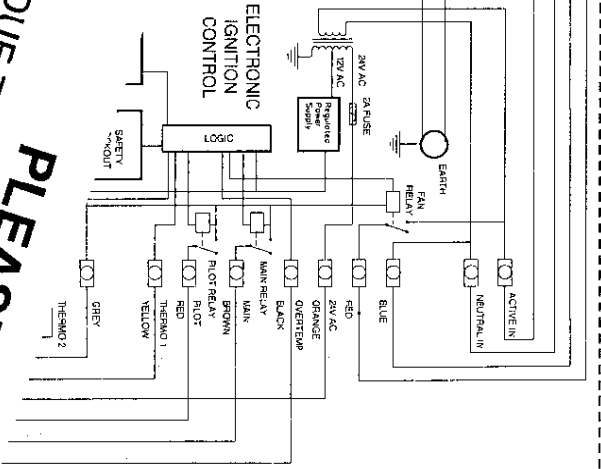

PLEASE NOTE:
DUE TO ELECTRONIC UPDATES,
THIS WIRING DIAGRAM IS NOW INVALID.
PLEASE REFER TO THE WIRING
DIAGRAM ON YOUR HEATER.

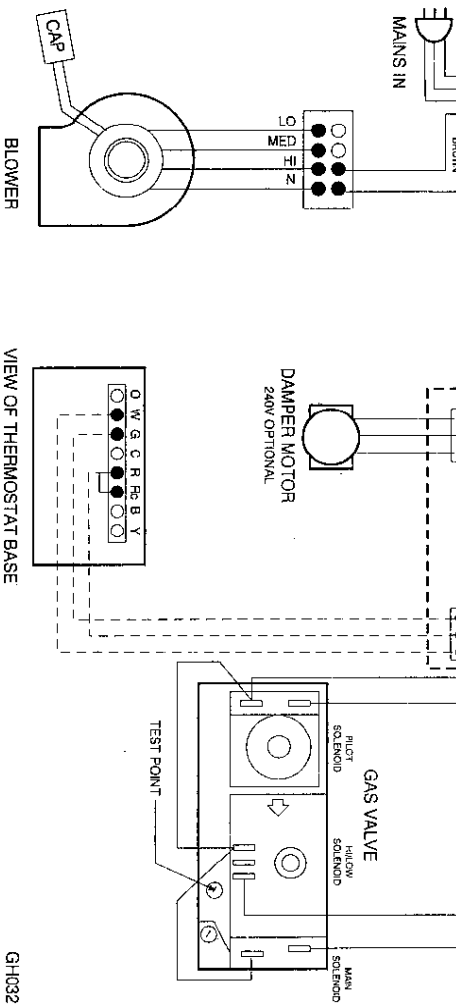
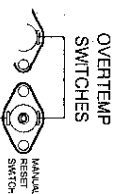

GH032

WARRANTY

The manufacturer warrants that the product is free from Defects in the material and factory workmanship. Subject to the terms of warranty, THE MANUFACTURER will repair or replace at its option, the product or any part thereof, which examination shows to be defective, for a period of Two (2) Years from the date of purchase.

Ten (10) years warranty is available on the following components.

1. BURNERS
2. HEAT EXCHANGER

Warranty on any replacement parts is limited to the balance of their original warranty period.

This is the sole warranty of the manufacturer, who is not responsible for any obligation, assumed or expressed by any other person or persons.

Conditions

The warranty is available to the first purchaser only, being the purchaser who purchases without the intent of reselling for profit.

The structural warranty covers any metal structural components which fail to perform their intended function due to faulty manufacture or deterioration, within the warranty period.

The warranty does not cover any component parts or equipment used in conjunction with the heater, which were not supplied by the manufacturer.

The warranty does not cover faulty installation, maintenance or abnormal conditions of service.

The warranty does not cover damage to the heater or other resulting from acts of god. The warranty shall not apply to the heater or any part thereof which in the opinion of the manufacturer has been subject to accident, alteration, abuse or misuse or unauthorised repair.

This warranty shall not be extended to any loss suffered by or resulting from the non operation of the heater or part thereof.

Travelling costs incurred for work beyond a 25km radius of an Authorised Braemar service agent must be met by the purchaser.

NOTE: Should you require warranty service for your Braemar heater, we recommend you first contact your local Braemar Dealer, they are best placed to attend to any problem no matter how small. If however a service call reveals no fault with your Braemar heater, you may well be charged for the call, even during the warranty period.



Proudly Australian Made
Since 1938