

Harness the
power of
cool, fresh air throughout your
home, all summer long!



up to

85% *cheaper*

to run than reverse
cycle air conditioning¹

100% *healthy*

fresh air - the **ONLY**
air to breathe!



Breezee
by SEELEY INTERNATIONAL

Braemar
by SEELEY INTERNATIONAL

coolair
by SEELEY INTERNATIONAL



The world's healthiest, coolest, quietest most
energy-efficient evaporative air conditioners ever!²

Harness the *power* of nature.

At Seeley, we harness the power of nature

Our evaporative air conditioning technology has been inspired by nature with ingenious design, incredible reliability and unsurpassed cooling performance delivering 100% fresh outside air - the only air to breathe!

Seeley International is renowned for world-class design and innovation, striking that delicate balance between form and function, just like nature.

We have a range of evaporative coolers that can seamlessly integrate with all roof lines without compromising on comfort, quality or environmental credentials, through to our traditional range that also deliver cool efficiency, for long lasting comfort for everyone in the home.

Since day one, over 50 years ago, our company has been about challenging mindsets and stretching the imagination. Trust, reliability, longevity and innovation, have been the cornerstones to our unrivalled success! It's no coincidence that Seeley International is the **most awarded** air conditioning manufacturer in Australia. And we export our amazing products all around the globe.

At Seeley International, we don't settle for ordinary, and neither should you.

Frank Seeley

AM, DUniv *Flin*, FAICD
Founder and Executive Chairman



Award Winning Company

Seeley International consistently wins awards for new product design, innovation and environmental friendliness. These awards include:



Front cover:

1. Seeley International's calculation based on approximate running cost figures from publicly sourced data.
2. Based on published research articles, NATA certified laboratory test results and publicly sourced data.

Evaporative air conditioning

The most healthy and energy efficient cooling experience for **everyone** in your home!

Evaporative air conditioning delivers a natural, exceptionally healthy cooling experience in the place where people spend **most** of their time - **HOME**.

Evaporative air conditioners use evaporation to help cool the air. Based on the principles of evaporation, hot and dry outside air is pumped through water-infused cooling pads. As the air is pushed through the cooling pads, the water evaporates and the heat in the air is absorbed, which lowers the air temperature. A fan then pushes the cool air throughout the home via a network of ducts.



Low running cost

Save up to 85% on energy bills when compared to a reverse cycle air conditioner³.



Delivers Safer-Air™

100% fresh, filtered outside air, expelling the stale recycled air.



Low maintenance

Innovative design, minimising long term servicing.



Minimal water usage

Evaporative air conditioning uses up to **94% less water** per year than a shower⁴.



Quiet to run

Experience how **cool and whisper quiet** it is in your home!



Built to last

Quality that lasts. Up to 7 years comprehensive warranty⁵.



Environmentally friendly

Produces up to 85% less CO₂ emissions⁷ - that's the equivalent of **planting 8 gum trees!**⁷

⁷Refer to page 5.



Alfresco living

Perfect for busy families where children and pets keep coming in and out.



Australian designed, made and owned!

Manufactured by family owned Seeley International, Australia's largest air conditioning manufacturer.



3. Seeley International's calculation based on approximate running cost figures from publicly sourced data. Comparison with 1.5 star not zoned ducted refrigerative system in a large size (220m²) 2-star pre 2005 house in a Melbourne climate, cooling all day on the weekend and in the mornings and evenings when internal temperatures are high, and an electricity tariff of 29.30c/kWh. Negligible water cost excluded.

4. Water use calculations for shower are based on shower water use for 4 people, 7 mins per person per day at 9L/min, over twelve months, calculated at 91,980 L. Water use calculations for Braemar unit LCQ450 evaporative air conditioner over twelve months are 5,405 L.

5. The warranty has terms and conditions, refer to page 23 for details.

Harness the *ultimate* in efficiency and sustainability

With energy prices escalating, evaporative cooling offers an energy-efficient solution that can save you up to 85% on your energy bills³.

Running costs per year³

Compared to a ducted reverse cycle system.

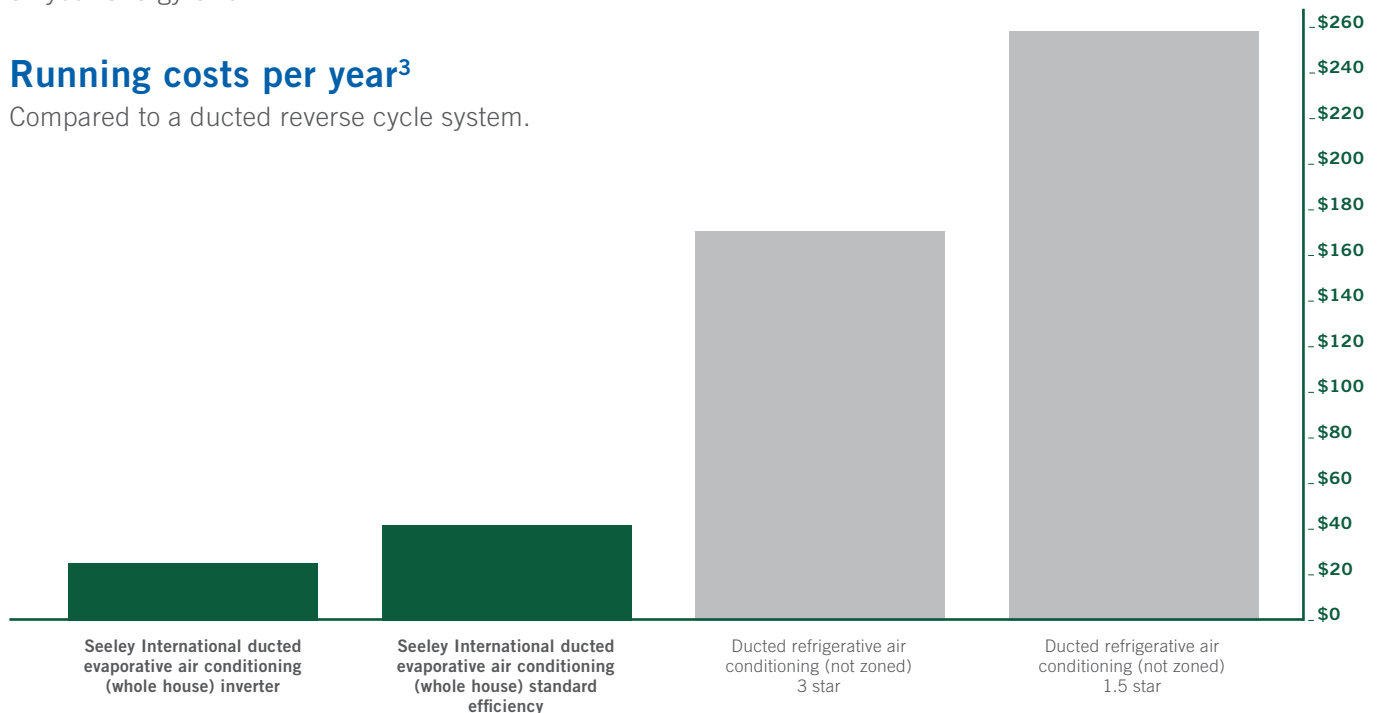

So if you want ultra-cool, healthy, 100% fresh air, around the clock with huge power savings, you can **have** it! But **only** if you harness the power of Breezair, Braemar or Coolair.



Minimal water usage

Our water saving features:

- Superior water distribution system
- Water quality monitoring
- Auto-Clean™ - Automatic water drainage

The result: Minimum water usage for maximum, fresh cooling power.

Water consumption comparison across household appliances⁴

Seeley Evaporative A/C⁴

Based on 12 months usage: **5,405 L/year**

Washing machine

Based on 70L/load, 5 loads per week: **18,200 L/year**

Toilet

35 flushes per week, per person in a 4 person household, average 5L per flush: **36,400 L/year**

Garden watering (including sprinklers)

120 mins per day at 20 litres per minute - 2x per week and 3x in summer months: **57,600 L/year**

9L/min water efficient shower head

4 people daily, taking 7 minute showers: **91,980 L/year**

3. Seeley International's calculation based on approximate running cost figures from publicly sourced data. Comparison with 1.5 star not zoned ducted refrigerative system in a large size (220m²) 2-star pre 2005 house in a Melbourne climate, cooling all day on the weekend and in the mornings and evenings when internal temperatures are high, and an electricity tariff of 29.30c/kWh. Negligible water cost excluded.

4. Water use calculations for shower are based on shower water use for 4 people, 7 mins per person per day at 9L/min, over twelve months, calculated at 91,980 L. Water use calculations for Braemar unit LCQ450 evaporative air conditioner over twelve months is 5,405 L.

Reduce your carbon footprint



The power consumption of just one ducted refrigerated air conditioner can result in up to 1.4 tonnes of harmful CO₂ being pumped into the atmosphere each year. By purchasing a Seeley International evaporative air conditioner, which uses water, a **renewable resource**, to cool, you'll **reduce your impact on the environment** by producing up to **85% less CO₂ emissions**⁵, when compared to a ducted reverse cycle air conditioner.

CO₂ Emissions (kg/Yr)⁵

Compared to ducted reverse cycle systems.

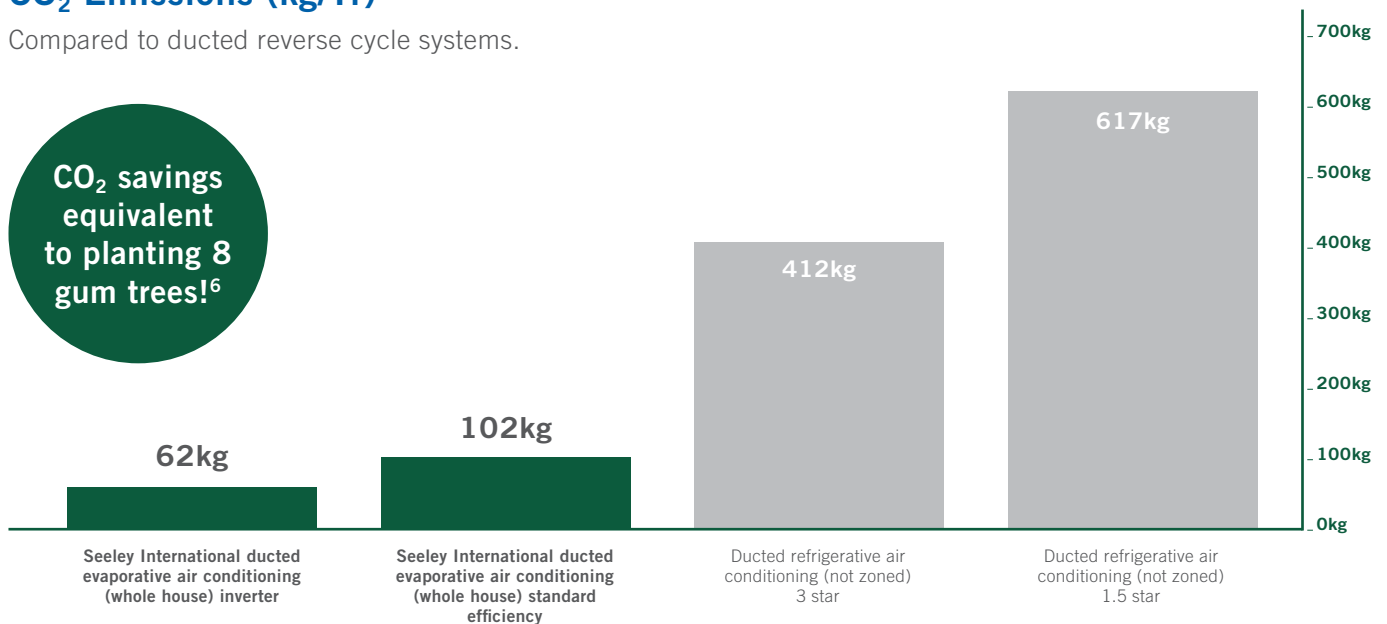

How do I choose?

An expert Seeley International Dealer will assist in evaluating your home to determine the most effective cooling capacity, the airflow, and size of the area you wish to cool, which will then identify the best suited model for your needs. Whilst it may seem that bigger can only be better, a correctly sized air conditioner for your home will run far more efficiently, which equates to maximised electricity cost savings.

- **Is your home well insulated?** This is a key consideration, as it impacts your home's ability to maintain its temperature. A well insulated home may need a lower capacity unit, in comparison to a poorly insulated home.
- **What climate is your home located in?** The hotter the climate, the greater the demand on your air conditioning.
- **What additional benefits are important to you?** Seeley International evaporative air conditioners offer additional technology benefits like winter seals, SuperStealth® fans, inverter motors, water savers, and architecturally designed units for greater aesthetic appeal. (Refer to our product selection guide on pages 20 and 21 for more information.)

5. Seeley International's calculation based on approximate greenhouse gas emissions figures from carbonpositiveaustralia.org.au/carbon-footprint-calculator/. Comparison with 1.5 star not zoned ducted refrigerative system in a large size (220m²) 2-star pre 2005 house in a Melbourne climate, cooling all day on the weekend and in the mornings and evenings when internal temperatures are high.

6. This is an estimate based on the CO₂ calculation above and using the data from forestlearning.edu.au, 'Carbon and its storage in forest and wood products' article, published 2011. Calculation based on a spotted gum tree that sequesters 72kg CO₂/YR.

Harness the *power* of Safer-Air™

Air quality is paramount for people's well-being

Australians spend between 80 to 100% of their time indoors, either at work or at home⁷, which demonstrates how important Indoor Air Quality (IAQ) is, when it comes to your own health and well-being, your ability to concentrate, learn, to be energetic and productive. Exposure to poor air quality for extended periods can lead to severe health problems.

IAQ is a high priority for buildings and work spaces under the building code, so it should also be taken seriously in the home environment, especially as it relates to the health and comfort of you and your family!

High levels of Carbon Dioxide (CO₂), Volatile Organic Compounds (VOCs) and Particulate Matter (PM) such as dust and pollens are directly linked to illness, low productivity, drowsiness, headaches, irritation of the eyes, ears, nose, and throat, and triggering of asthma and allergies.

What is Safer-Air™?

Removes CO₂ in the home from re-breathed air

Reverse cycle air conditioners re-circulate air, some of which has been re-breathed for hours, and maybe even days. This re-circulated air contributes to a build-up of CO₂ in the home and CO₂ is known to have adverse effects on human health and well-being.

Increases oxygen levels for greater vitality and productivity

Evaporative air conditioners continually cool and deliver 100% fresh, filtered, outside air that contains natural levels of oxygen, replenished through your whole home every 3 minutes⁸, or less.

Removes other indoor pollutants

Dust particles and most pollen grains are 10–70 µm in diameter which are filtered or flushed out of your home from the air delivered by our evaporative cooling products.

Maximum air ventilation

Our evaporative air conditioners replace the stale air in your whole home every 2 to 3 minutes⁸. Creating a positive air pressure that pushes out stale air and pollutants through open windows and doors, while the system is cooling your whole home.



7. Source: <https://www.health.vic.gov.au/your-health-report-of-the-chief-health-officer-victoria-2018/environmental-health/healthy-indoor> (2023)

8. Based on airflow data (litres/sec) from Braemar LCQI and Breezair XTR coolers in an average house with 2.4m ceilings and floor area of 150m².

Australian *designed, made* and owned!

Built by Australians, for the harsh Australian climate

Seeley International is a proudly 100% Australian owned company, designing and manufacturing world-leading air conditioning products for Australia and the world. As Australia's largest air conditioning manufacturer, we are a global leader in developing ingenious, energy-efficient cooling and heating products. Being made in Australia, you can rely on build quality, longevity and the availability of parts and after sales service, for many years to come. We're extremely passionate, and dedicated to strengthening the Australian economy, supporting local employment and building on the skills of our workforce.

Australian designed, made and owned!



Bruce - Production Operator

Enjoy *high capacity* cooling

Breakthrough Black Magic® Mini-Cell Chillcel® pad technology

Exclusive small cell design to achieve more saturation of the pads and provides cutting-edge high capacity cooling.

Our revolutionary Black Magic® Mini-Cell Chillcel® pads deliver superlative cooling and have transformed the aesthetics of our coolers as they seamlessly blend into their surroundings.

Maintains our global leading Mini-Cell Chillcel® pad technology, which increases surface area of the fully wetted pads by 25%, dramatically increasing cooling capacity and efficiency beyond belief!

The only evaporative cooling medium of its kind. Fully manufactured in Adelaide, Australia to address the harsh Australian climate.

Standard inclusion in all Breezair, Braemar and Coolair units.

25%
MORE
cooling
surface
area

Harness the *power* of Breezair

Cooling that's out of this world, but won't cost the earth!



The coolest ever evaporative air conditioner.

A showcase of innovation

Australian engineering at its finest. Breezair is Seeley International's premium, world-leading evaporative air conditioner brand, offering advanced technology and revolutionary design for fixed evaporative whole of home cooling.

The Breezair evaporative air conditioner was the world's first corrosion-free, all-plastic rooftop cooler to be made, completely revolutionising the market in the early 80's. The move away from corroding metal parts, to durable plastic coolers became, and remains, the industry standard today.

Every element of the Breezair evaporative air conditioning system comes together to ensure that your family will enjoy the benefits of natural and energy efficient **fresh air** cooling.

Breezair benefits include:

- Patented Hushpower® direct drive or InvertaCool® motors
- Patented ultra quiet centrifugal or axial fan configurations
- Watermiser® uses the minimum amount of water to achieve maximum high efficiency cooling.
- Auto-cleanse™ - Automatic water draining when the system is not in use avoids algae growth.
Only available with selected MagIQtouch controller models. Regular maintenance (typically every 2 years for domestic use) is still required.
- The coolest, quietest and most energy efficient evaporative air conditioner range in the world!¹



The warranty has terms and conditions, refer to page 23 for details.

1. Based on published research articles, NATA certified laboratory test results and publicly sourced data.

Breezair range

Extraordinaire®

Redefining the future for whole-of-home cooling.

- Architecturally designed, with a sleek, single piece outer cover. Hugging the roof line, from 10 to 40 degrees.
- Patented axial SuperStealth® fan delivers whisper quiet operation.
- Super-efficient InvertaCool® motor.
- Breakthrough Black Magic® Mini-Cell Chillcel® pad technology provides cutting edge cooling capacity and aesthetics.
- Cooling capacity up to 17.4kW. Airflow up to 2900L/sec.

Available colours⁹

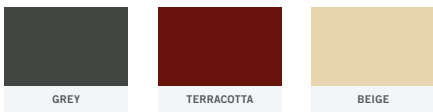

Extraordinaire®

Never settle for ordinary!



Supercool®

- Extra thick Chillcel® pads on the two larger models for additional cooling capacity (EXS200 & EXS220)
- Optimised energy efficiency and airflow with quiet operation, from the innovative inverter motor and centrifugal fan.
- Cooling capacity up to 15.1kW. Airflow up to 2540L/sec.

Available colours⁹



9. Colours may vary.



Incorporating **InvertaCool®** technology

- Quieter operation.
- Greater air flow control.
- Ultra-energy efficient, lower carbon emissions.
- Lower power bills.

Breezair

Features and benefits

Highly durable and non-corrodible outer casing

- High performance Permatuf® polymer construction will not corrode or rust.

Supercool® series fan is ultra-quiet

- Designed to deliver optimum air output at all times.
- Ultra-quiet centrifugal fan with 10 speeds.
- Use “Fan Only” mode (no water) to blow fresh air through the home and expel odours.

Hushpower® direct drive InvertaCool® motor uses less energy

- Exclusive to Breezair and manufactured in Australia.
- Incredibly quiet and efficient throughout its operating range.
- Unsurpassed reliability.
- Corrosion proofed throughout with parts that won't rust.

Weather Seal® reduces draughts and dust

- Automatic sealing system.
- Reduces need for winter cover.

Power control module helps save water and power

- Advanced electronics ensure maximum efficiency.
- Microprocessor constantly analyses water quality, water consumption and power output.
- Incredibly smart, exceptionally reliable and super durable.

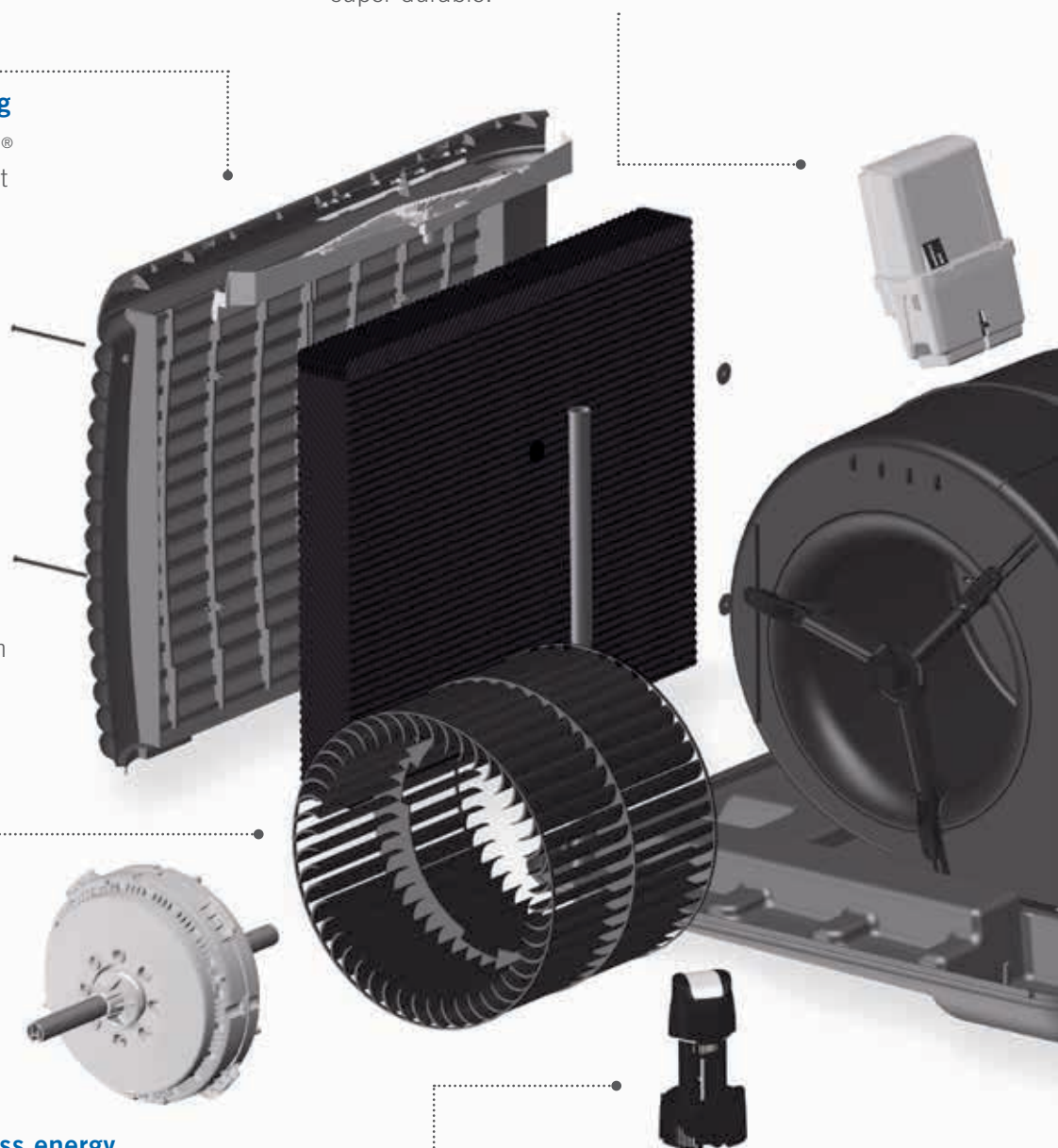

Tornado® pump that won't block

- Australian designed and manufactured.
- Exceptional reliability in extreme conditions.
- Dual directional – it can't block!



Drain and clean function

- Auto-cleanse™ – Automatic water draining when the system is not in use it avoids algae growth.

Only available with selected MagIQtouch controller models. Regular maintenance (typically every 2 years for domestic use) is still required.

Black Magic® MINI-CELL CHILLCEL® pad technology

- Exclusive small cell design provides cutting-edge high capacity cooling.
- For more information refer to **page 7**.

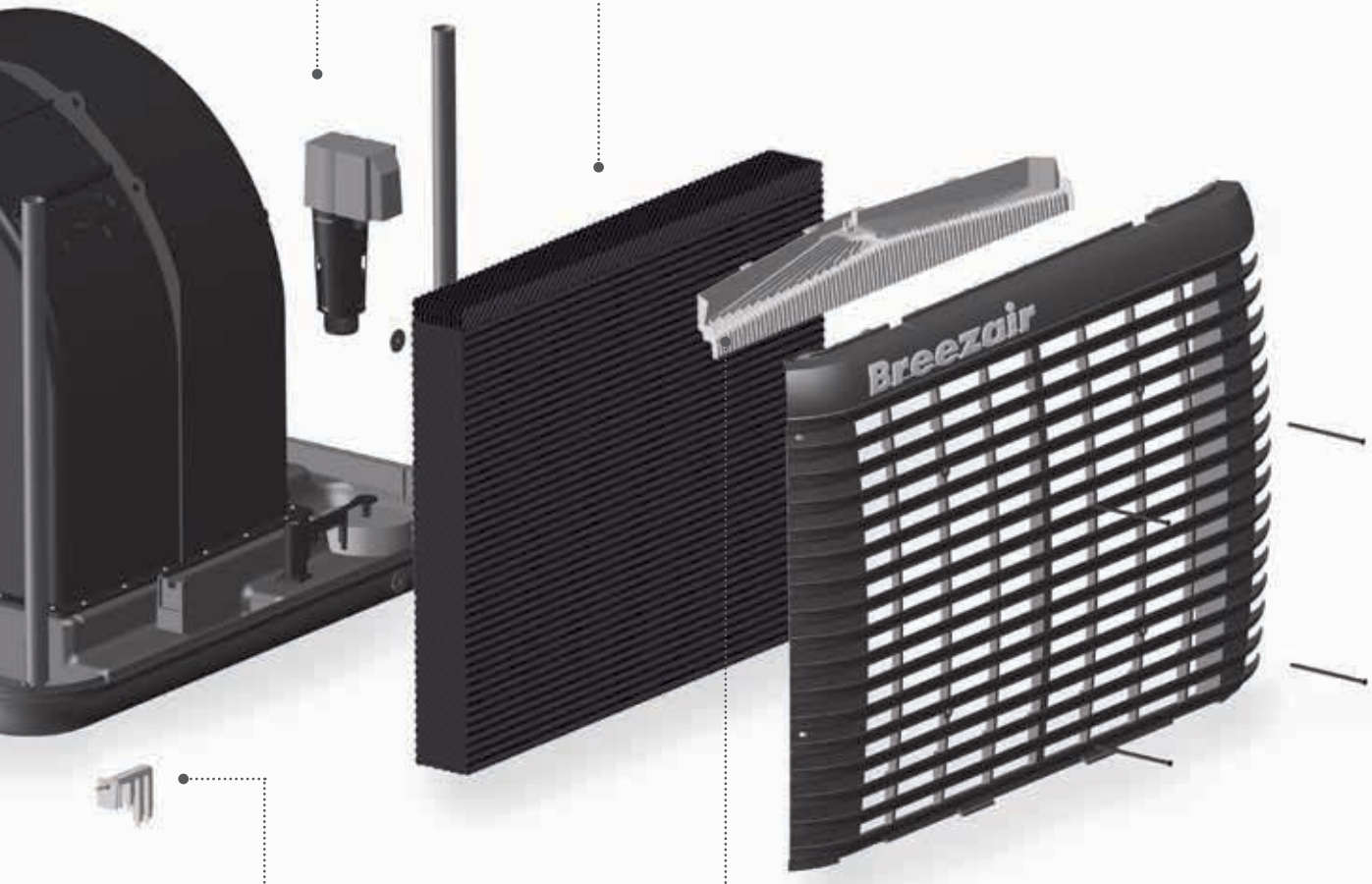

Watermiser® saves water

- Uses the minimum amount of water to achieve maximum high efficiency cooling.
- Water quality monitoring to maximise water savings.
- Leak detection when the unit is in use.

Bushfire Protection Firewall Ember Screen (optional extra)

- Helps guard against ember attack in bushfires.
- Turn to **page 22** for more information.

Exceptional water distribution, increases cooling effect

- Unique to Breezair, this Australian design ensures constant, even pad saturation – increasing the cooling effect and outperforming competitor products.

Harness the *power* of Braemar

Cooling that's out of this world, but won't cost the earth!



The coolest, compact, low profile air conditioner in the world!

A reputation built on quality and endurance

Founded in 1938 and being the oldest of Seeley International's brands, Braemar remains one of Australia's most recognised and trusted brand names today.

Backed by an 80 year history of innovation and success, the Braemar range is the recipient of many industry awards.

Braemar benefits:

- SuperStealth® InvertaCool® motor and SuperStealth® axial fan for high energy-efficiency and whisper quiet operation.
- AutoWinterseal® automatically closes off the air conditioner ducts when not in use ensuring year round comfort.



The warranty has terms and conditions, refer to page 23 for details.

Braemar range

Evolution

The coldest conventional sloped tank evaporative air conditioner on the market.

- InvertaCool® motor, using far less energy than a standard motor.
- SuperStealth® axial fan for high energy-efficiency and whisper quiet operation.
- AutoWinterseal®, automatically closes off the air conditioner ducts when not in use.
- Cooling capacity up to 13.2kW. Airflow up to 2850L/sec.

Available colours⁹



SuperStealth®

The world's first high-performance inverter axial evaporative air conditioner.

- Patented ultra quiet SuperStealth® fan (quieter than the standard stealth fan).
- AutoWinterseal®, automatically closes off the air conditioner ducts when not in use.
- WaterManager™ water quality monitoring to maximise water savings.
- Outstanding high-performance cooling.
- Cooling capacity up to 14.3kW. Airflow up to 3070L/sec.

Available colours⁹



Paradigm®

- High efficiency and cooling performance.
- Premium water management system.
- Cooling capacity up to 14.1kW. Airflow up to 2810L/sec.

Available colours⁹



9. Colours may vary.

Exceptional water distribution

The water distribution system includes a combination of pressurised and free-flowing water systems, providing:

- Even water flow over the sides of the top panel, ensures maximum pad area and maximum cooling at all times.
- Australian designed, world patented, free flow, water distributor ensures constant, even pad saturation increasing the cooling capacity and outperforming competitor products.

Black Magic® MINI-CELL CHILLCEL® pad technology

- Exclusive small cell design provides cutting-edge high capacity cooling.
- For more information refer to **page 7**.

Power control module helps save water and power

- Microprocessor constantly analyses water quality, water consumption and power output.

Tornado® pump that won't block

- Australian designed and manufactured.
- Exceptional reliability in extreme conditions.
- Dual directional – it can't block!



Auto Cleanse™ – Auto water draining keeps your system clean

- Empties the reservoir automatically when system is not in use, leaving it clean and dry.
- Ensures the system always operates at maximum efficiency, while using the minimum amount of water.
- Helps to reduce seasonal maintenance¹⁰ as required by some other brands.

10. Seasonal maintenance does not replace regular maintenance of the unit as required for peak performance.



UV stabilised and corrosion free

- The cabinet and water reservoir components are injection moulded structural foam polypropylene (Permatuf®) and are UV stabilised and non-corrodible.

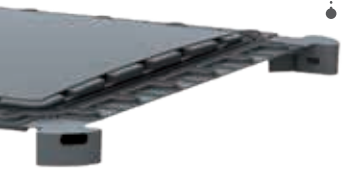

SuperStealth® Technology (Evolution & SuperStealth® models)

- Advanced aerodynamic design.
- SuperStealth® InvertaCool® motor and SuperStealth® fan for high energy efficiency and whisper quiet operation.



WaterManager™ saves water

- Uses the minimum amount of water to achieve high efficiency cooling.
- Water quality monitoring to maximise water savings.
- Keeps your system clean on the inside.

AutoWinterseal® reduces draughts and dust

- Automatically closes off the air conditioning ducts when not in use.
- Reduces winter chills entering your home.
- Ensures comfort all year round.

Harness the *power* of Coolair

Cooling that's out of this world, but won't cost the earth!

Accessible evaporative air conditioning

The Coolair brand became part of the Seeley International suite in 1997 and was quickly redeveloped to incorporate the all-plastic, corrosion-free construction which Seeley had pioneered.

The brand maintains its ethos of affordable effective cooling; presenting a good, value for money unit for those wanting to enjoy the benefits of evaporative cooling, without the cost of more advanced features.

CPQ Series

Coolair Evaporative air conditioners are very affordable, representing the HIGHEST VALUE-FOR-MONEY coolers.

- Variable speed motor.
- Stealth® fan for quiet operation.
- Highly durable and non-corrodible outer casing.
- Operates with a bleed valve water management system – especially suitable for harsh water quality regions.
- AutoWinterseal®, automatically closes off the air conditioning ducts when not in use.
- Drain valve water management can be fitted as optional.



Available colours⁹



GREY



TERRACOTTA

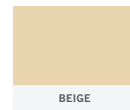

BEIGE

Flexible control with MagIQcool®

- Easy to use.
- Set your preferred temperature level on the clever wall mounted control and Coolair will do the rest – quickly, cleanly and reliably.
- Maintain your desired comfort level with four convenient modes to choose from – cool, vent, auto and timer.



The warranty has terms and conditions, refer to page 23 for details.



⁹ Colours may vary.

Complimentary products for heating

Braemar Dominator Series®

Install a Braemar Dominator Series® with your evaporative air conditioner and you will have one of the most efficient heating and cooling solutions on the market!

- Hyper-efficiency and Safer-Air™ from your evaporative air conditioner in summer.
- Powerful warmth of Dominator Series® in winter.
- Plus the added advantage of having refrigerated cooling on the few humid summer days where evaporative technology is less effective.



 **Micro-channel heat exchanger**
Dominator Series® are fitted with a unique, specifically designed micro-channel heat exchanger, maximising the heating capacity and efficiency.

 **Upgrade to the Braemar Zone Controller¹⁰**
Switch between different rooms in your home and control the settings in each zone via the wired Zone Controller and RF sensors. The system comes with 4 RF sensors standard and can be expanded to accommodate up to 8 zones¹¹.

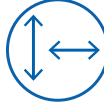
 **Convenient size**
Designed to fit in the exact same position as a ducted gas heater unit for easy replacement.

 **Inverter performance**
Quicker and finer temperature control and comfort – with significantly lower running costs.

 **R32 refrigerant**
More environmentally friendly, R32 refrigerant global warming potential is 68% lower than R410A, with up to 30% reduction in charging quantity needed.

Braemar Ducted Gas Heating

A Braemar ducted gas heater will complement your evaporative cooling system:

- Warm and cosy in winter; fresh and cool in summer!
- MagiQtouch® controller will seamlessly control **both** heater and cooler systems.
- Braemar has an extensive range of high efficiency ducted gas heaters across multiple energy star ratings.

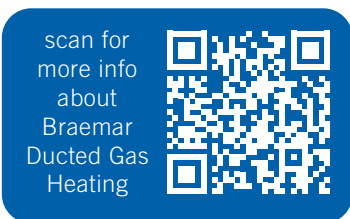

10. Zoning is an optional extra. Additional costs apply.
11. Additional RF sensors will incur an extra cost.

Harness the *simplicity* of **MAGIQTOUCH®** controller

Touch screen technology

Smart, sophisticated and incredibly intuitive, your MagIQtouch® controller is an upgrade from the manual controller and makes operating your evaporative air conditioner a breeze. Control the temperature, fan speed and many more features on a user friendly touch screen. The discreet and modern design will blend seamlessly into the décor of your home.



Main features



Program mode

Programmable 7 day, 4 time period program, customisable to suit your lifestyle (including a temporary over-ride function).



Touch screen functionality

All functions and operations are only a touch away, with the easily navigated interface.



Auto-clean™ function

World's first fully automated pad cleansing capability enables you to set and forget, ensuring your cooling pads remain clean, fresh and functional all summer long, season after season¹².



Energy saving quiet night mode

A comfortable night's sleep that won't cost the earth. The energy saving quiet night mode automatically reduces fan speed during the night for even greater economy at lower noise levels.



Cooling & Heating

Control both your cooling and heating from one MagIQtouch® controller.



Useful settings

Access additional features such as child lock, and servicing information.

Optional extra: MagIQtouch® air sensor

The MagIQtouch® air sensor monitors temperature and humidity levels. It allows you to mount your MagIQtouch® controller in the most convenient place in your home, as the MagIQtouch® air sensor will then take over temperature control from the MagIQtouch® controller. This can then be located in the best place in the house to ensure ultimate cooling comfort for everyone.



¹². Only for cooler models fitted with the water management system. Ask your dealer for further information.

Harness the *power* of Wi-Fi and wireless

Controller upgrade options

If you choose a MagIQtouch® controller you receive a touch screen that is hard-wired into your home, fixed to your wall, where it best suits your needs. This model of MagIQtouch® controller can be upgraded to a Wi-Fi enabled touch screen.

Option 1



Wi-Fi enabled¹³ touch screen:

- Take complete control of your comfort at home, at all times.
- Upgrade to a Wi-Fi module (sold separately) to work with your hard-wired MagIQtouch Controller¹⁴ enabling you to control your cooling directly from your personal device through our smart app.
- The Smart app is available on Android and IOS devices.



Available for download now on iOS and Android

Control your
cooling from
ANYWHERE



Option 2

Unable to have a hard-wired controller? No problem, MagIQtouch® also has a wireless touch screen option.



Wireless touch screen:

- Battery operated wireless controller using Radio Frequency technology.
- Ideal for renovations, or where access for cabling is limited.
- Easier to install, the RF option also provides up to 2 primary controllers.
- Can control the entire system from 2 locations, rather than 1; an ideal solution for larger, or two storey homes.
- Not compatible with Wi-Fi module.



13. Requires MagIQtouch® Wi-Fi kit, compatible MagIQtouch® controller and MagIQtouch® account to operate. Additional costs may apply.

14. MagIQtouch® Wi-Fi Module is not compatible with MagIQtouch wireless controller.

Product Selection Guide

Model	Breezair Extraordinaire®			Breezair Supercool®				Braemar Evolution		
	XTR3000	XTR4000	XTR5000	EXS160	EXS180	EXS200	EXS220	LPQV350	LPQV450	LPQV550
Cooling Capacity (kW)	12.4	14.5	17.4	10.8	11.6	14.3	15.1	10.4	11.8	13.2
Airflow (L/s @ 80Pa) ¹⁵	2100	2480	2900	1720	2070	2320	2540	2010	2390	2850
Nominal motor power (W)	430	600	950	550	750	1100	1500	430	600	950
Width (mm)	1160	1160	1160	1160	1160	1160	1160	1150	1150	1150
Depth (mm)	1400	1400	1400	1160	1160	1160	1160	1150	1150	1150
Height – Front (mm)	840	840	840	860	860	860	860	730	730	730
Height – Rear (mm)	550	550	550	860	860	860	860	380	380	380
Operating weight (kg)	86	86	86	90	90	94	94	86	86	86
Weather Seal® / AutoWinterseal®	✓	✓	✓	✓	✓	✓	✓	✓	✓	✓
Adjustable float for different roof angles	✓	✓	✓							
Advanced salinity control management system	✓	✓	✓	✓	✓	✓	✓	✓	✓	✓
Auto drain valve	✓	✓	✓	✓	✓	✓	✓	✓	✓	✓
Black ice integrated water distribution system	✓	✓	✓							
Black Magic® Mini-Cell Chillcel® technology	✓	✓	✓	✓	✓	✓	✓	✓	✓	✓
Extra thick Chillcel® pads	✓	✓	✓			✓	✓			
Discreet drain outlet	✓	✓	✓							
Low profile sloping base	✓	✓	✓					✓	✓	✓
Permatuf® polymer molded cabinet	✓	✓	✓	✓	✓	✓	✓	✓	✓	✓
Standard bleed water management				○	○	○	○	○	○	○
Superlock™ dropper system	✓	✓	✓							
SuperStealth® fan & InvertaCool® inverter motor	✓	✓	✓					✓	✓	✓
Centrifugal fan & inverter motor				✓	✓	✓	✓			
Standard induction motor										
High static fan (160-240pa)	✓	✓	✓	✓	✓	✓	✓	✓	✓	✓
Tornado® pump	✓	✓	✓	✓	✓	✓	✓	✓	✓	✓
Double pump outlet	✓	✓	✓					✓	✓	✓
Unique bonnet style cabinet design	✓	✓	✓							
5 sided inlet system for maximum draw air flow	✓	✓	✓							
WaterManager™ system	✓	✓	✓	✓	✓	✓	✓	✓	✓	✓
MaglQcool® wall controller								○	○	○
MaglQtouch® standard controller available	○	○	○	○	○	○	○	○	○	○
MaglQtouch Wi-Fi module or RF controller options available	○	○	○	○	○	○	○	○	○	○
Firewall kit available				○	○	○	○			

Optional Add-ons

✓ - comes standard ○ - optional extra with additional cost

15. Airflow performances at 80Pa - the equivalent duct static pressure of typical ducted residential multiple outlet installations. The above data was drawn from Meridian Test Laboratory's test analysis. The testing was performed by a NATA accredited laboratory to the requirements of the Australian standard AS2913-2000 "Evaporative Air Conditioning Equipment." Achievable with ambient 38 °C DB, 21 °C WB, room temperature 27.4 °C.

 InvertaCool® technology used in these models. See page 9 for details.

Model	 Braemar SuperStealth®				Braemar Paradigm			Coolair CPQ			
	LCQV250	LCQV350	LCQV450	LCQV550	LCQ350	LCQ450	LCQ550	CPQ450	CPQ700	CPQ850	CPQ1100
Cooling Capacity (kW)	8.1	9.9	13.5	14.3	10.2	13.2	14.1	8	9.5	11.8	13.3
Airflow (L/s @ 80Pa) ¹⁵	1500	1990	2620	3070	1980	2560	2810	1570	2000	2560	2710
Nominal motor power (W)	340	430	600	950	430	600	950	340	430	600	750
Width (mm)	1150	1150	1150	1150	1150	1150	1150	1150	1150	1150	1150
Depth (mm)	1150	1150	1150	1150	1150	1150	1150	1150	1150	1150	1150
Height – Front (mm)	685	685	835	835	685	835	835	685	685	835	835
Height – Rear (mm)	685	685	835	835	685	835	835	685	685	835	835
Operating weight (kg)	88	88	91	91	80	89	91	78	79	87	89
Weather Seal® / AutoWinterseal®	✓	✓	✓	✓	✓	✓	✓	✓	✓	✓	✓
Adjustable float for different roof angles											
Advanced salinity control management system	✓	✓	✓	✓	✓	✓	✓				
Auto drain valve	✓	✓	✓	✓	✓	✓	✓	○	○	○	○
Black ice integrated water distribution system											
Black Magic® Mini-Cell Chillcel® technology	✓	✓	✓	✓	✓	✓	✓	✓	✓	✓	✓
Extra thick Chillcel® pads											
Discreet drain outlet											
Low profile sloping base											
Permatuf® polymer molded cabinet	✓	✓	✓	✓	✓	✓	✓	✓	✓	✓	✓
Standard bleed water management	○	○	○	○	○	○	○	✓	✓	✓	✓
Superlock™ dropper system											
SuperStealth® fan & InvertaCool® inverter motor	✓	✓	✓	✓							
Centrifugal fan & inverter motor											
Standard induction motor					✓	✓	✓	✓	✓	✓	✓
High static fan (160-240pa)	✓	✓	✓	✓							
Tornado® pump	✓	✓	✓	✓	✓	✓	✓	✓	✓	✓	✓
Double pump outlet											
Unique bonnet style cabinet design											
5 sided inlet system for maximum draw air flow											
WaterManager™ system	✓	✓	✓	✓	✓	✓	✓	○	○	○	○
MaglQcool® wall controller	○	○	○	○	○	○	○	✓	✓	✓	✓
MaglQtouch® standard controller available	○	○	○	○	○	○	○	○	○	○	○
MaglQtouch Wi-Fi module or RF controller options available	○	○	○	○	○	○	○	○	○	○	○
Firewall kit available	○	○	○	○	○	○	○	○	○	○	○

Optional Add-ons

✓ - comes standard ○ - optional extra with additional cost

Optional Extras

Keep your home secure

Did you know you can cool your home without leaving your doors and windows open?

Cost effective and easy to install, the **Security Relief Vent™** allows you to run your evaporative air conditioner while you are out, with all your windows and doors safely closed and locked.

Your home will **stay** cool, because the **cool** exhaust air is released into the hot roof space, cooling everything while you're out.

When you return home, if you wish, simply open up your windows and doors as normal - either way, you will **maintain** the delivery of fresh, cool air **throughout** your home.



Bushfire protection

Firewall Ember Screen (optional extra)

- Helps guard against ember attack in bushfires.
- Made from non-combustible mesh.
- Maximum aperture of 2mm.
- Can be fitted to existing cooler pad frames.
- Minimal reduction in air flow of around 5%.
- To meet BAL ratings, the cooler **also** requires a Firewall Auto Seal installed.
- Fitting both Ember Screen and Auto Seal to comply with BAL ratings will reduce airflow by up to 15%.

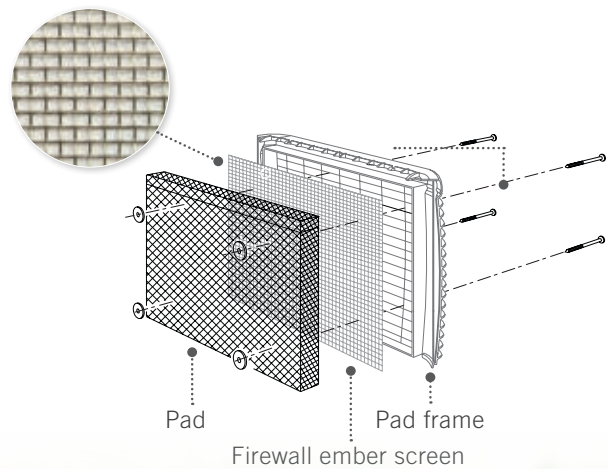

Warranty Terms

7 Year Warranty - Breezair & Braemar

7 year Comprehensive Warranty¹⁶, 10 year cover on all structural components, plus a hefty 25 year cover against corrosion, on its Permatuf[®] cabinet.

16. The 7 year comprehensive warranty is available **only** if the product is first purchased from Seeley International, by Seeley International Participating Dealers **and not** through distributors/wholesalers or trade installers. Warranty is calculated at 7 years from date of purchase. The warranty has terms and conditions, including the requirement for regular servicing of the product in accordance with the owner's manual.

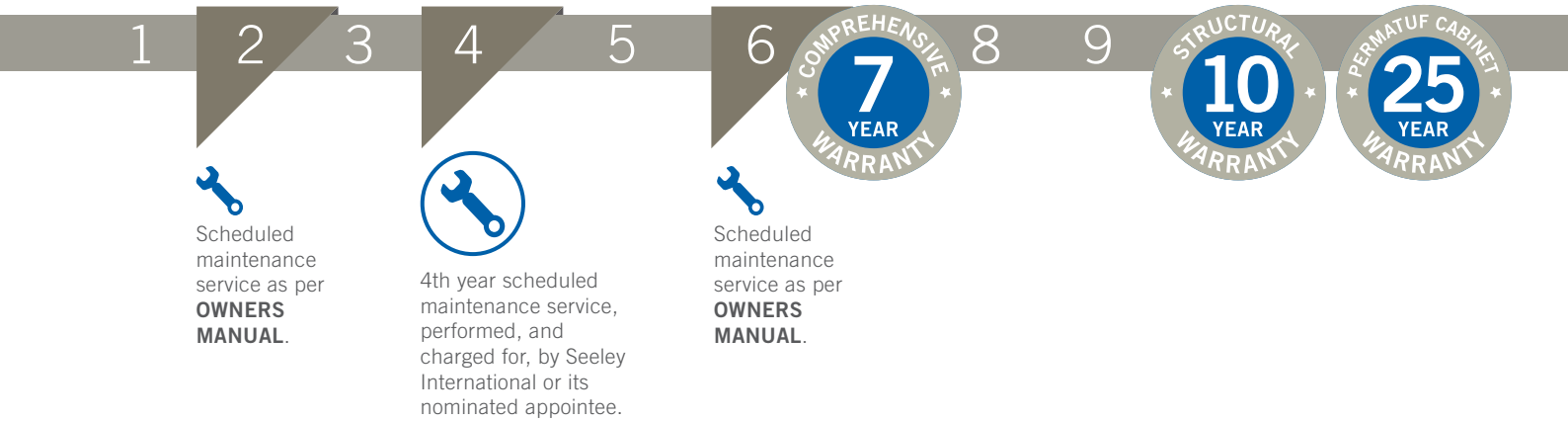

5 Year Warranty - Coolair¹⁷

5 year Warranty, 10 year cover on all structural components, plus a hefty 25 year cover against corrosion, on its Permatuf[®] cabinets.



17. Coolair 5 Year only warranty applies to products purchased from October 1st 2020.



Harness the *power* of nature



BREEZAIR

Ducted Evaporative Air Conditioning

BRAEMAR

Ducted Evaporative Air Conditioning | Ducted Gas Heating
Reverse Cycle Air Conditioning | Gas Wall Furnaces and Space Heaters

THE CLIMATE WIZARD

Micro-Core® Technology

SUPERCool

Ducted Evaporative Air Conditioning

COOLAIR

Ducted Evaporative Air Conditioning

COOLERADO

Indirect Evaporative Air Conditioning

AIRA

Direct and Indirect Evaporative Air Conditioning | Ducted Gas Heating
Commercial Gas Space Heating | Energy Recovery Systems

INTEGRATED COMFORT INCORPORATED (ICI)

Dual Cool® Patented Dual Evaporative pre-cooling products

seeleyinternational.com/residential

1300 360 815

Seeley International Pty Ltd

ABN 23 054 687 035

112 O'Sullivan Beach Road, Lonsdale, SA 5160

Phone: (08) 8328 3850

seeleyinternational.com

Information in this brochure was correct at the time of preparation. E & OE



With the generous support of our Australasian dealers we are proud to be the National Variety Bash partner supporting kids in need across Australia.



Cat No BML01 REV I DEALER (1125)