

## TECHNICAL DATA SHEET – CW-80 WITH MULTI-MAGIC CONTROLS

### GENERAL

Climate Wizard coolers are characterised by the supply of 100% fresh, cool, outside air with NO additional moisture added, with greatly reduced energy consumption relative to an equivalent refrigerated system performing the same duty.

The cooler comprises of two supply air fans, four exhaust air fans, an indirect heat exchanger pack, integrated water reservoir, pump, and water management system.

CW-80S can be operated in “Supercool” mode producing even colder supply air with added moisture (direct cooling). Supercool coolers have an additional pump and Chillcel® pads.

### CABINET

The cabinet is constructed from 304 stainless steel incorporating the motor / fan assemblies, non-corrodible heat exchange cores and other ancillary equipment all supported by a heavy gauge galvanised base frame for structural stability.

Forklift tine channels are provided within the base frame to facilitate transport and lifting.

Components are effectively treated to ensure corrosion resistance and mechanical fasteners are zinc coated, stainless steel or aluminum.

Connection interface surfaces are provided for the outlet supply air ductwork to be fitted using established industry practices.

### FANS & MOTORS

The fans are a multi-blade, centrifugal type with backward curved blades. They have a cast aluminum coated rotor and aluminum impellers which are individually statically and dynamically balanced. The fans are directly mounted to the electric motors.

The electric motors are high efficiency, inverter driven and responsive to 0-10V control signals to implement speed control that delivers optimum efficiency at lower speed operation.

Standard and high capacity fans available.

### HEAT EXCHANGE CORE

The heat exchange cores are designed to facilitate heat exchange between the wet air passages and the dry air passages such that high efficiency heat transfer takes place without any additional moisture.

They are designed to provide long life and consistent, long term high efficiency.

Supercool models are fitted with additional Chillcel® fabricated, honeycomb direct cooling pads.

### WATER MANAGEMENT SYSTEM

The water supply connection is a ¾” fitting that connects directly to the internally mounted solenoid valve.

Water is held in an internal reservoir manufactured from molded polymer to ensure durability and corrosion resistance.

Heat exchange core saturation is achieved through internally mounted pumps delivering water to a specially designed non-clog water distribution system guaranteeing continuous uniform flow.

The wet components of each pump are manufactured from stainless steel and the pumps are driven by a 3-phase industrial, fully enclosed fan cooled electric motor with thermal overload protection. Easily cleanable in line strainers are provided for both the incoming water supply and the water distribution system.

An electronic water management system controls the maximum salinity level and chlorination of the reservoir water through continuous monitoring and replenishment.

The reservoir is drained by an electric drain valve that responds to the water management control system. The design of the reservoir ensures that no water remains after draining.

### AIR FILTERS

Intake air is filtered through aluminum framed, washable pleated filters protected by intake louvers to minimise intrusion of rain.

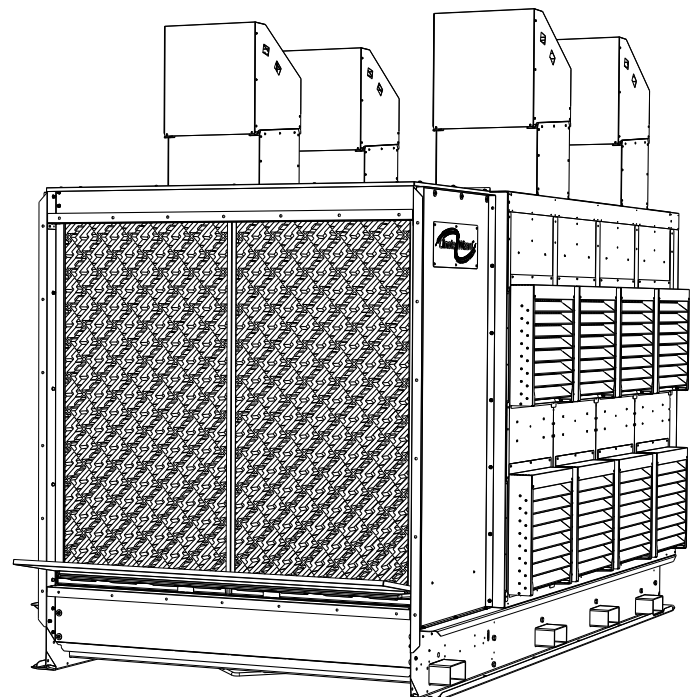

**TECHNICAL DATA SHEET – CW-80 WITH MULTI-MAGIC CONTROLS**

**TOP**

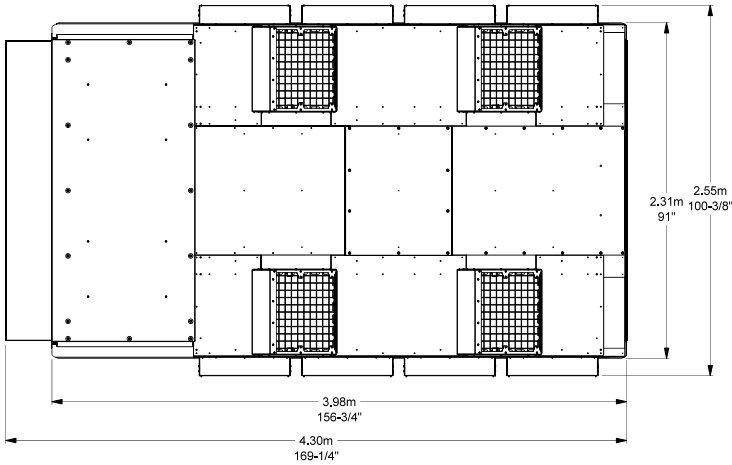

**BACK**

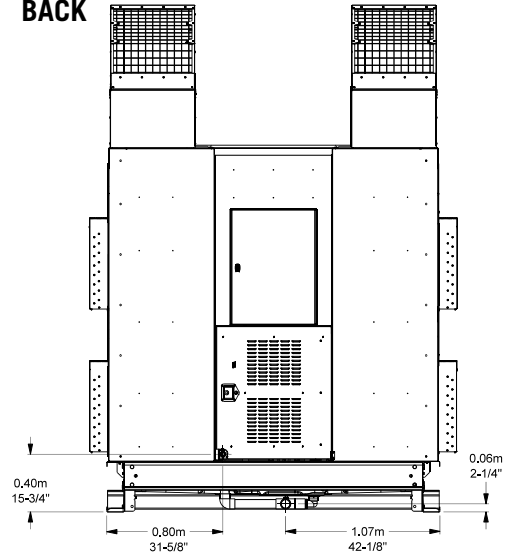

**SIDE**

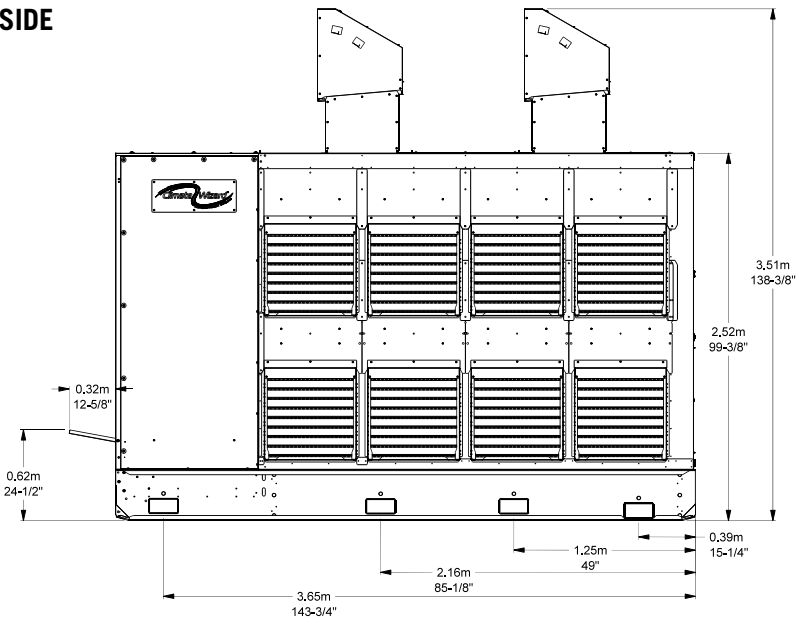

**FRONT**

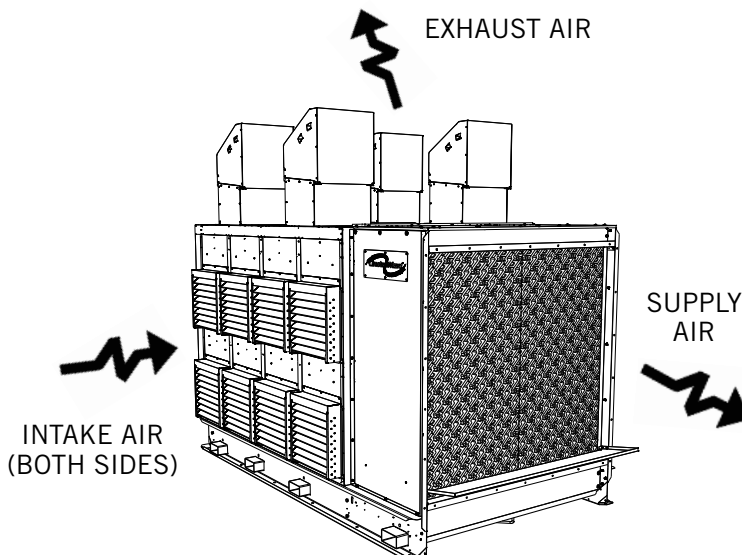
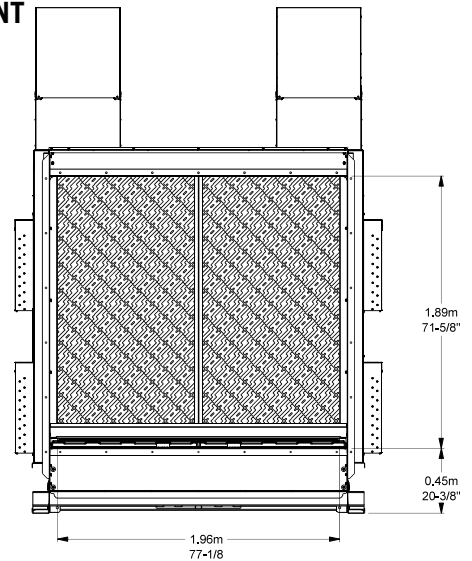

**NOTE:** Installers must allow adequate access to and around the cooler for Maintenance.

Provision must be made for access to power, control, water supplies and drains.

Refer to the Installation Manual for full details.

**TECHNICAL DATA SHEET – CW-80 WITH MULTI-MAGIC CONTROLS**

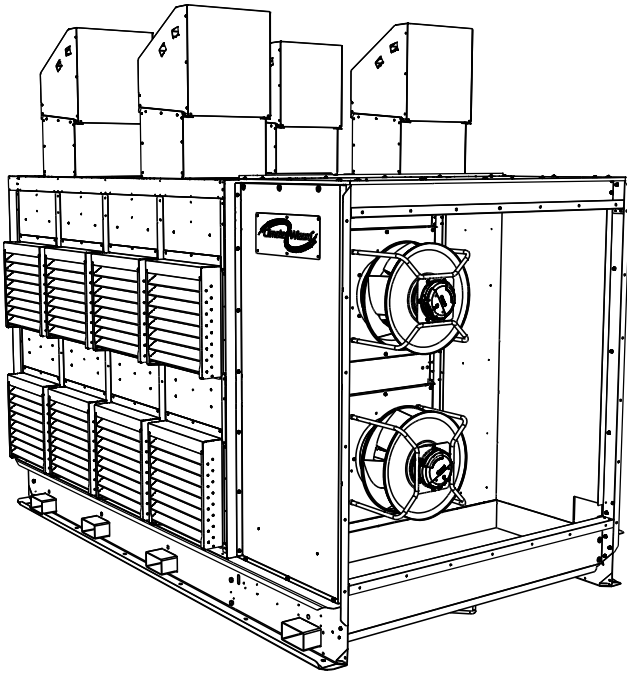

**CW-80 IEC STANDARD CAPACITY FANS**

- Primary Indirect Evaporative Cooling Stage
- No added Moisture

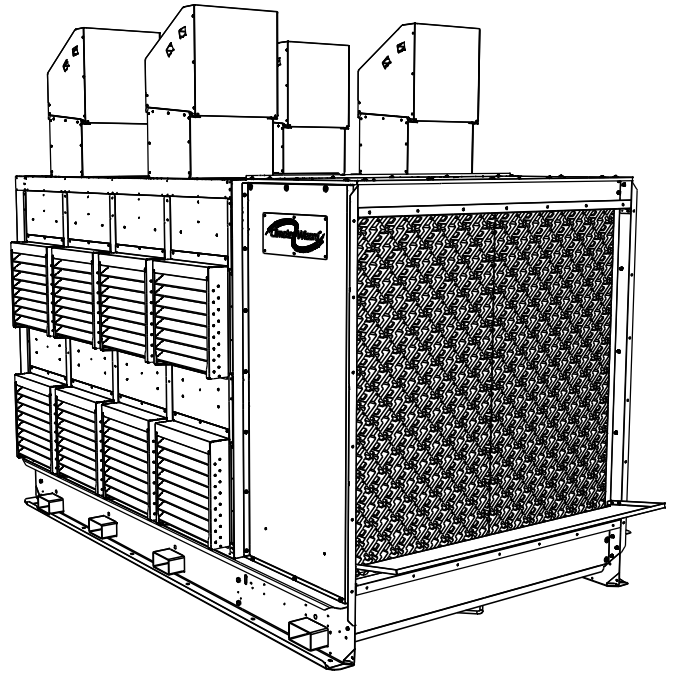

**CW-80 SUPERCool STANDARD CAPACITY FANS**

- Primary Indirect Evaporative Cooling Stage
- Secondary Direct Evaporative Cooling Stage
- Highest Energy Efficiency

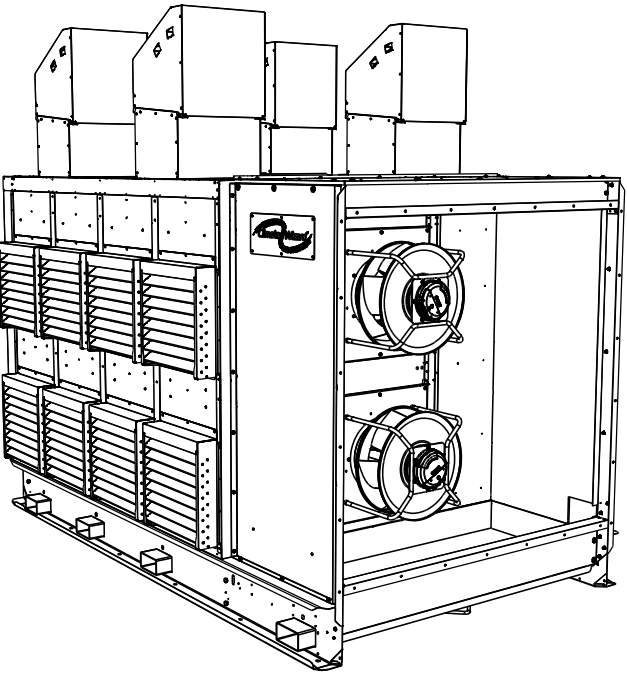

**CW-80 IEC HIGH CAPACITY FANS**

- Primary Indirect Evaporative Cooling Stage
- No added Moisture
- Highest External Static Pressure Capacity

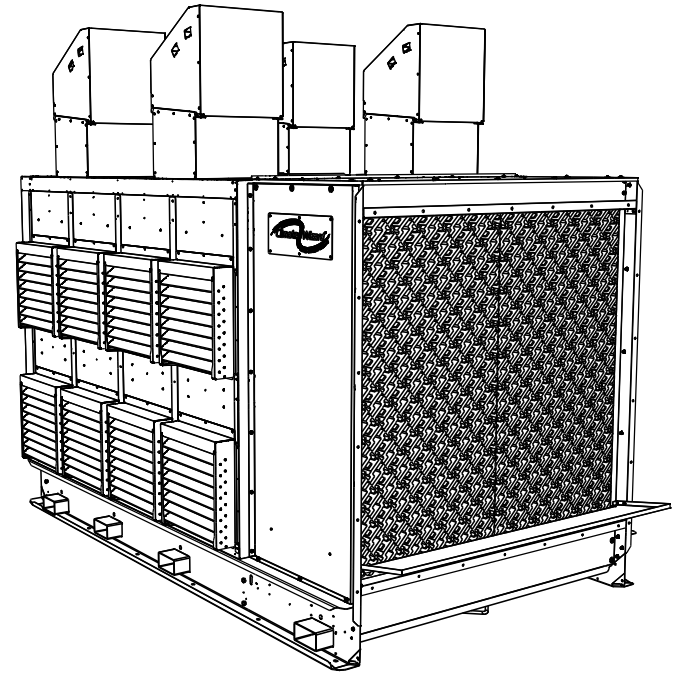

**CW-80 SUPERCool HIGH CAPACITY FANS**

- Primary Indirect Evaporative Cooling Stage
- Secondary Direct Evaporative Cooling Stage
- Highest Cooling Capacity

## TECHNICAL DATA SHEET – CW-80 WITH MULTI-MAGIC CONTROLS

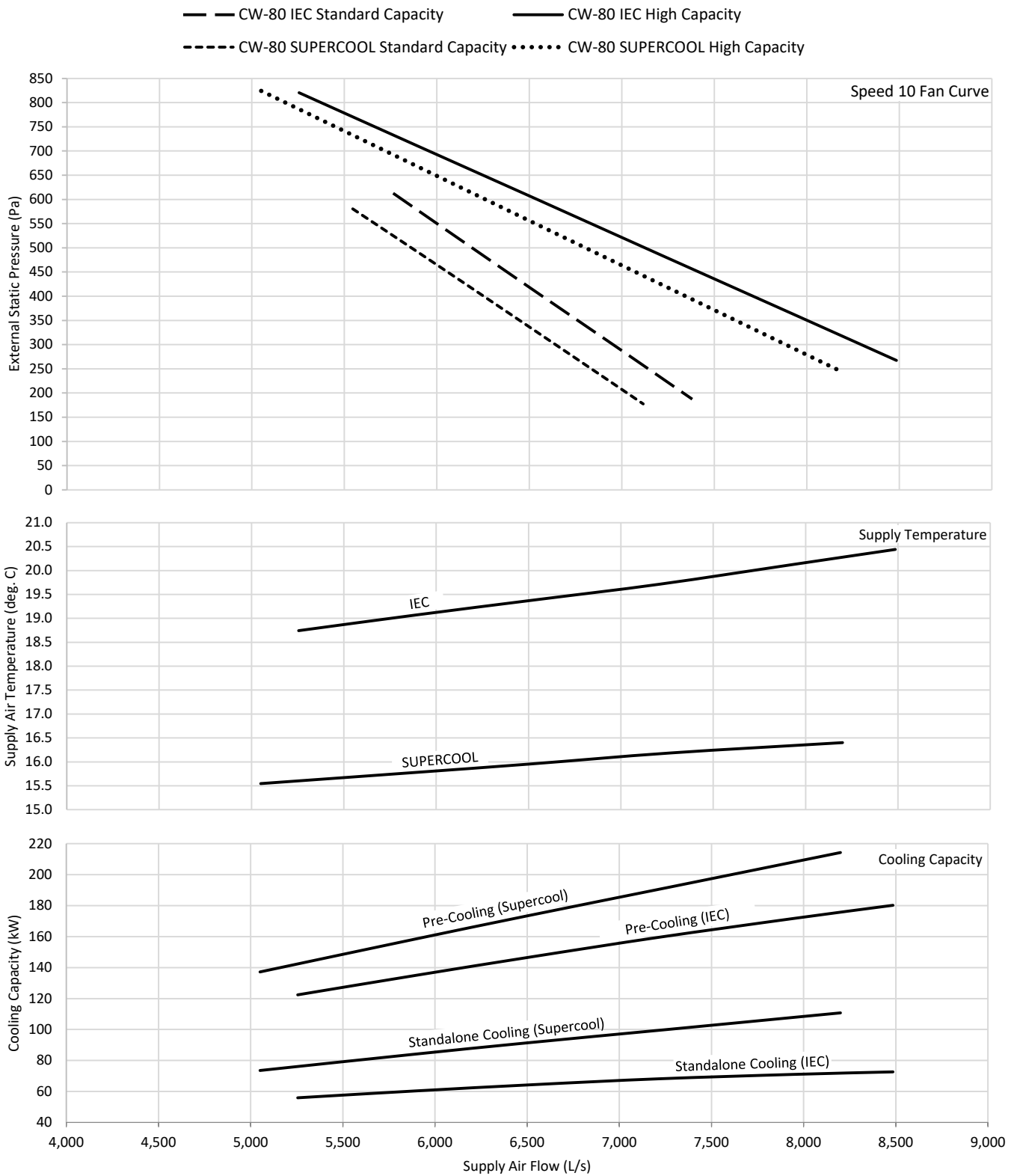

		Maximum Speed Sound Power Level (dB re 1 pW)							Total
		Octave Band Centre Frequency							
FREQUENCY (Hz)		125	250	500	1k	2k	4k	8k	
CW-80	Radiated	73	86	86	90	87	83	77	94

## TECHNICAL DATA SHEET – CW-80 WITH MULTI-MAGIC CONTROLS

MODEL:			CW-80 IEC STANDARD CAPACITY FANS	CW-80 SUPERCOOL STANDARD CAPACITY FANS
SERVICES	Electrical	Voltage	380-440 V / 3~ / 50-60Hz	380-440 V / 3~ / 50-60Hz
		Rated Current	26 A	27 A
		Input Power	12.5 kW	12.5 kW
	Water	Supply	30 L/min MINIMUM 45 L/min RECOMMENDED @ 85 kPa - 800 kPa	30 L/min MINIMUM 45 L/min RECOMMENDED @ 85 kPa - 800 kPa
		Max Temperature	40 °C	40 °C
		Inlet	3/4" Male BSP	3/4" Male BSP
		Drain	2" Flexible Coupling	2" Flexible Coupling
	Duct Connections	Drain Flow Rate	40 L/min	40 L/min
		Supply Air	Side Discharge 1890 x 2068mm	Side Discharge 1890 x 2068mm
	Exhaust Air	4x Top Discharge Vents	4x Top Discharge Vents	
ENVIRONMENT	Maximum Inlet Air Temperature		50 °C	50 °C
AIR SYSTEMS	Supply Air Fan/Motor	Fan	2x 560mm Centrifugal	2x 560mm Centrifugal
		Motor	3.5 kW	3.5 kW
		Control	0-10V Variable Speed	0-10V Variable Speed
		Maximum Speed	1750 rpm	1750 rpm
	Exhaust Air Fan/Motor	Fan	4x 355mm Centrifugal	4x 355mm Centrifugal
		Motor	1.7 kW	1.7 kW
		Control	0-10V Variable Speed	0-10V Variable Speed
		Maximum Speed	2600 rpm	2600 rpm
Air Filters	Inlet	ISO Coarse Washable 622 x 622 x 44mm - Qty 16	ISO Coarse Washable 622 x 622 x 44mm - Qty 16	
HEAT EXCHANGERS	Indirect Evaporative		16 Cores	16 Cores
	Direct Evaporative		NONE	2 Chillcel Pads
WATER SYSTEMS	Tank (Reservoir) Capacity		180 L	180 L
	Inlet Valve		24 VAC Solenoid Valve	24 VAC Solenoid Valve
	Pump Indirect Heat Exchangers		1x 75 LPM @ 24.7m Head 380-440V / 3~ / 50-60 Hz Input Power 0.75 kW	1x 75 LPM @ 24.7m Head 380-440V / 3~ / 50-60 Hz Input Power 0.75 kW
	Pump Direct Heat Exchangers		NONE	1x 38 LPM @ 13.8m Head 380-440V / 3~ / 50-60 Hz Input Power 0.25 kW
	Salinity Management		Conductivity Probe	Conductivity Probe
	Chlorinator		230V, 50-60Hz	230V, 50-60Hz
	Drain Valve		12 VAC Vertical	12 VAC Vertical
DIMENSIONS	Shipping	Note: Exhaust Fans/ Motors, Weatherseals & Filters shipped loose.	3980mm (L) x 2310mm (W) x 2550mm (H)	3980mm (L) x 2310mm (W) x 2550mm (H)
	Operating		3980mm (L) x 2550mm (W) x 3515mm (H)	3980mm (L) x 2550mm (W) x 3515mm (H)
WEIGHT	Shipping	exc. Loose items	2000 kg	2100 kg
	Operating	inc. Water & Extras	2700 kg	2850 kg

# TECHNICAL DATA SHEET – CW-80 WITH MULTI-MAGIC CONTROLS

## CW-80 IEC STANDARD CAPACITY FANS

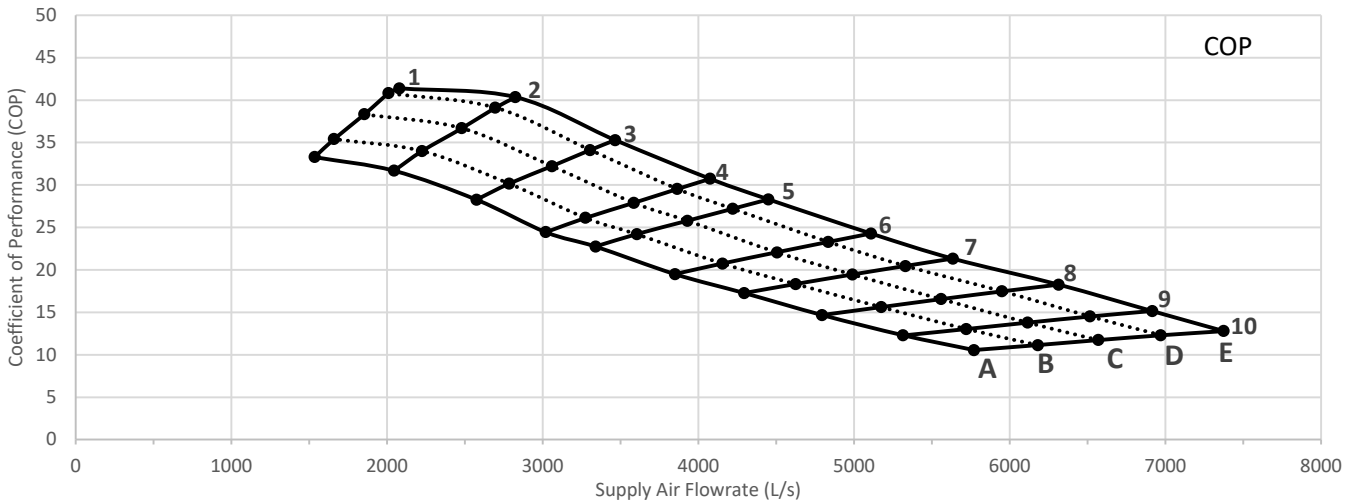
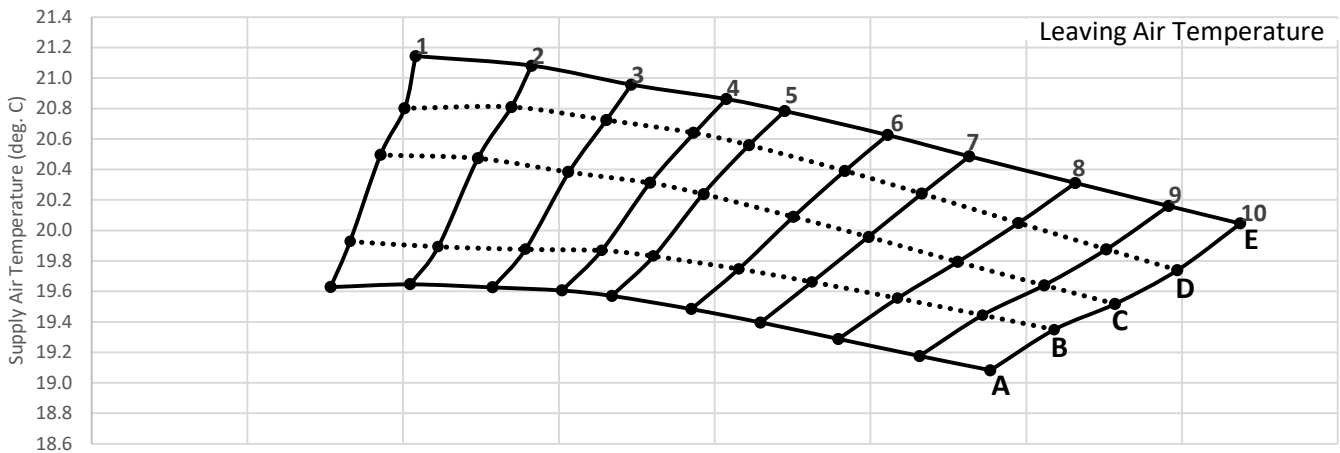
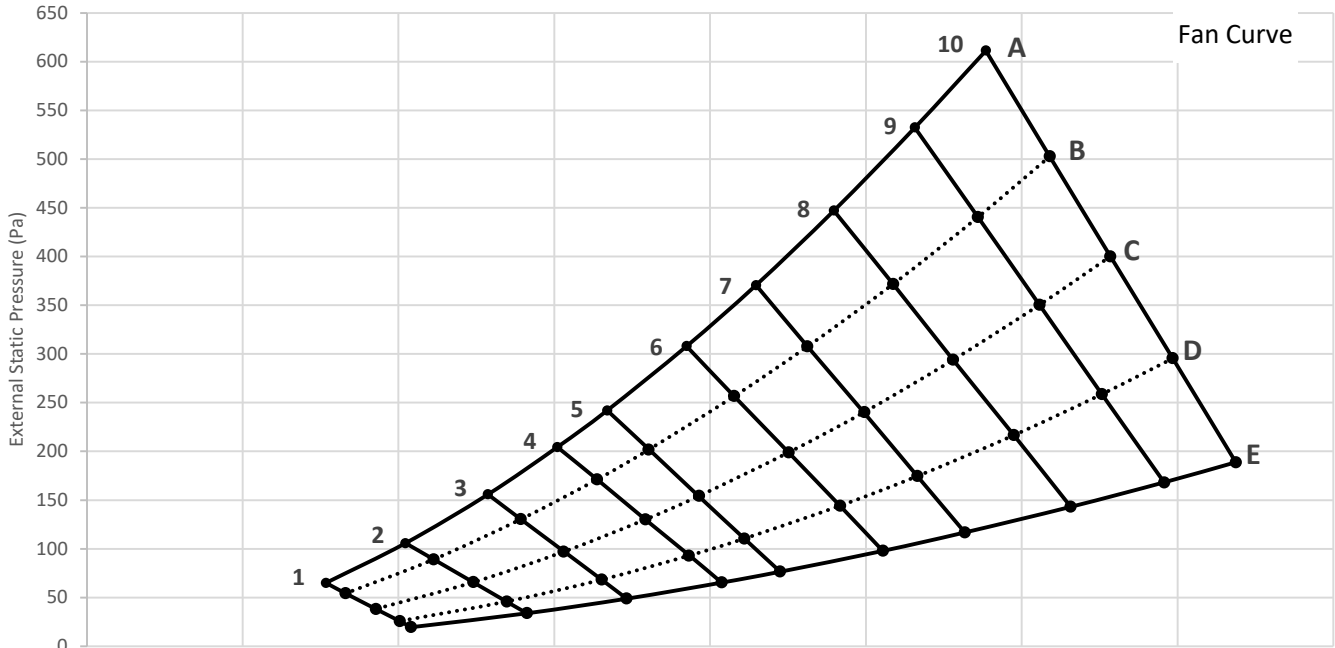

# TECHNICAL DATA SHEET – CW-80 WITH MULTI-MAGIC CONTROLS

## CW-80 SUPERCOOL STANDARD CAPACITY FANS

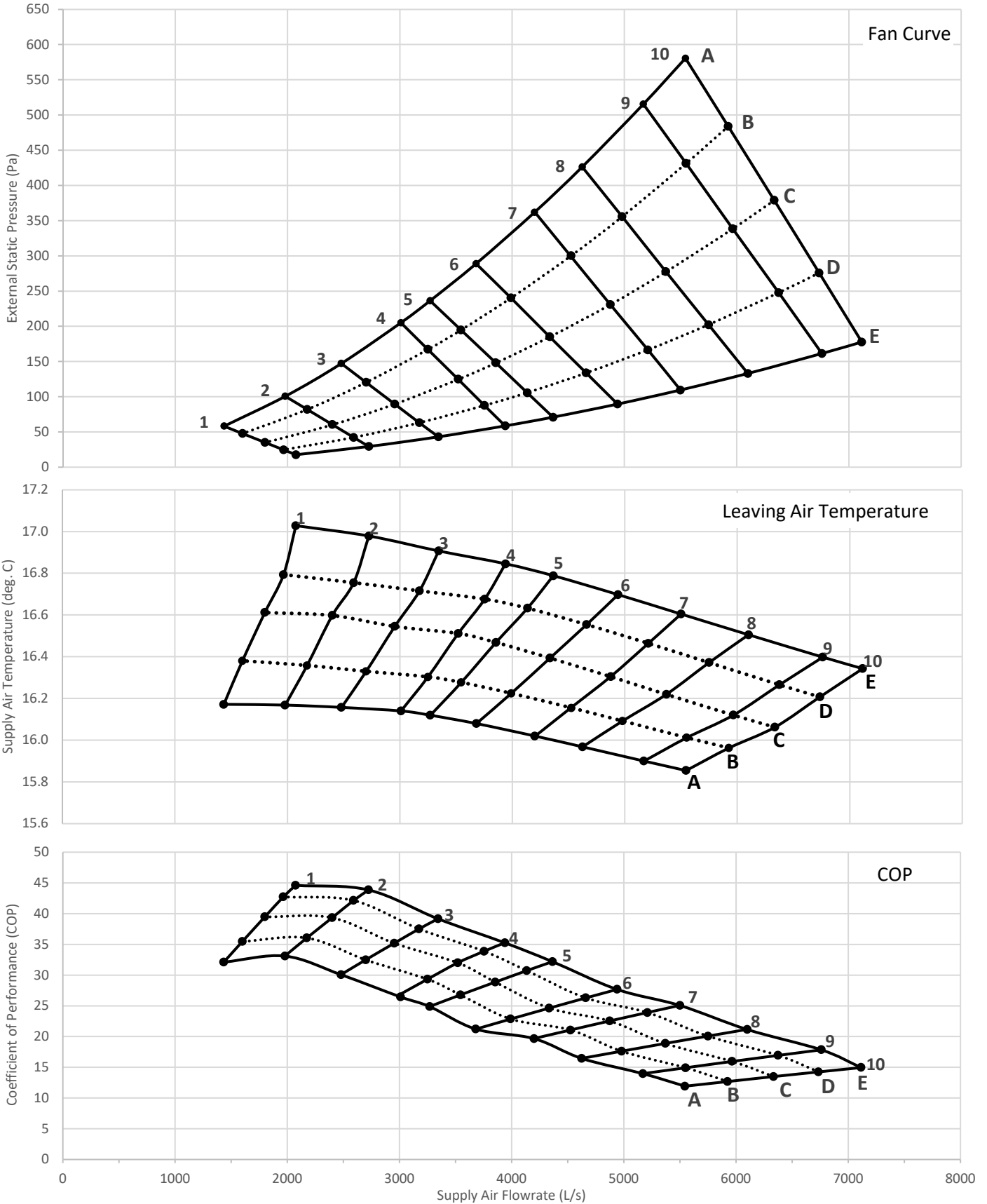

## TECHNICAL DATA SHEET – CW-80 WITH MULTI-MAGIC CONTROLS

CW-80 IEC STANDARD CAPACITY SPEED 10 PERFORMANCE SUMMARY*					
	A	B	C	D	E
EXTERNAL STATIC PRESSURE (Pa)	610	505	400	295	190
SUPPLY AIR FLOWRATE (L/s)	5800	6200	6600	7000	7400
SUPPLY AIR FLOWRATE (m <sup>3</sup> /h)	20,900	22,300	23,800	25,200	26,600
EXHAUST AIR FLOWRATE (L/s)	5000	4800	4900	4800	4600
EXHAUST AIR FLOWRATE (m <sup>3</sup> /h)	18,000	17,300	17,600	17,300	16,600
IEC LEAVING AIR TEMPERATURE (°C)	19.1	19.3	19.5	19.7	20.0
STANDALONE COOLING CAPACITY (kW)	59	61	64	66	67
PRE-COOLING CAPACITY (kW)	133	140	148	155	161
INPUT POWER (kW)	12.5	12.5	12.5	12.5	12.5
STANDALONE COP	5	5	5	5	5
PRE-COOLING COP	11	11	12	12	13
WATER CONSUMPTION (L/hr)	240	245	250	255	260

CW-80 SUPERCOOL STANDARD CAPACITY SPEED 10 PERFORMANCE SUMMARY*					
	A	B	C	D	E
EXTERNAL STATIC PRESSURE (Pa)	580	485	380	275	180
SUPPLY AIR FLOWRATE (L/s)	5500	5900	6300	6700	7100
SUPPLY AIR FLOWRATE (m <sup>3</sup> /h)	19,800	21,200	22,700	24,100	25,600
EXHAUST AIR FLOWRATE (L/s)	4500	4500	4500	4400	4300
EXHAUST AIR FLOWRATE (m <sup>3</sup> /h)	16,200	16,200	16,200	15,800	15,500
IEC LEAVING AIR TEMPERATURE (°C)	19.2	19.4	19.7	19.9	20.1
IDEAL LEAVING AIR TEMPERATURE (°C)	15.9	16.0	16.1	16.2	16.3
STANDALONE COOLING CAPACITY (kW)	78	83	88	92	96
PRE-COOLING CAPACITY (kW)	147	157	167	177	186
INPUT POWER (kW)	12.5	12.5	12.5	12.5	12.5
STANDALONE COP	6	7	7	7	8
PRE-COOLING COP	12	13	13	14	15
WATER CONSUMPTION (L/hr)	255	265	275	285	295

\* Leaving Air Temperatures, Cooling Capacities and Water Consumption valid at design condition of: 38 °C dry-bulb, 21 °C wet-bulb, 27.4 °C relief temperatures

INPUT POWER (kW)					
SPEED	CW-80 IEC STANDARD CAPACITY	CW-80 SUPERCOOL STANDARD CAPACITY	SPEED	CW-80 IEC STANDARD CAPACITY	CW-80 SUPERCOOL STANDARD CAPACITY
10	12.5	12.5	5	3.3	3.5
9	9.9	9.9	4	2.8	2.9
8	7.4	7.5	3	2.0	2.2
7	5.6	5.7	2	1.4	1.6
6	4.4	4.6	1	1.0	1.2

## TECHNICAL DATA SHEET – CW-80 WITH MULTI-MAGIC CONTROLS

MODEL:			CW-80 IEC HIGH CAPACITY FANS	CW-80 SUPERCOOL HIGH CAPACITY FANS
SERVICES	Electrical	Voltage	380-440 V / 3~ / 50-60Hz	380-440 V / 3~ / 50-60Hz
		FLA	29 A	30 A
		Input Power	14 kW	14 kW
	Water	Supply	30 L/min MINIMUM 45 L/min RECOMMENDED @ 85 kPa - 800 kPa	30 L/min MINIMUM 45 L/min RECOMMENDED @ 85 kPa - 800 kPa
		Max Temperature	40 °C	40 °C
		Inlet	3/4" Male BSP	3/4" Male BSP
		Drain	2" Flexible Coupling	2" Flexible Coupling
	Duct Connections	Drain Flow Rate	40 L/min	40 L/min
		Supply Air	Side Discharge 1890 x 2068mm	Side Discharge 1890 x 2068mm
		Exhaust Air	4x Top Discharge Vents	4x Top Discharge Vents
ENVIRONMENT	Maximum Inlet Air Temperature		50 °C	50 °C
AIR SYSTEMS	Supply Air Fan/Motor	Fan	2x 560mm Centrifugal	2x 560mm Centrifugal
		Motor	3.5 kW	3.5 kW
		Control	0-10V Variable Speed	0-10V Variable Speed
		Maximum Speed	1750 rpm	1750 rpm
	Exhaust Air Fan/Motor	Fan	4x 355mm Centrifugal	4x 355mm Centrifugal
		Motor	1.7 kW	1.7 kW
		Control	0-10V Variable Speed	0-10V Variable Speed
		Maximum Speed	2600 rpm	2600 rpm
Air Filters	Inlet	ISO Coarse Washable 622 x 622 x 44mm - Qty 16	ISO Coarse Washable 622 x 622 x 44mm - Qty 16	
HEAT EXCHANGERS	Indirect Evaporative		16 Cores	16 Cores
	Direct Evaporative		NONE	2 Chillcel Pads
WATER SYSTEMS	Tank (Reservoir) Capacity		180 L	180 L
	Inlet Valve		24 VAC Solenoid Valve	24 VAC Solenoid Valve
	Pump Indirect Heat Exchangers		1x 75 LPM @ 24.7m Head 380-440V / 3~ / 50-60 Hz Input Power 0.75 kW	1x 75 LPM @ 24.7m Head 380-440V / 3~ / 50-60 Hz Input Power 0.75 kW
	Pump Direct Heat Exchangers		NONE	1x 38 LPM @ 13.8m Head 380-440V / 3~ / 50-60 Hz Input Power 0.25 kW
	Salinity Management		Conductivity Probe	Conductivity Probe
	Chlorinator		230V, 50-60Hz	230V, 50-60Hz
	Drain Valve		12 VAC Vertical	12 VAC Vertical
DIMENSIONS	Shipping	Note: Exhaust Fans/ Motors, Weatherseals & Filters shipped loose.	3980mm (L) x 2310mm (W) x 2550mm (H)	3980mm (L) x 2310mm (W) x 2550mm (H)
	Operating		3980mm (L) x 2550mm (W) x 3515mm (H)	3980mm (L) x 2550mm (W) x 3515mm (H)
WEIGHT	Shipping	exc. Loose items	2000 kg	2100 kg
	Operating	inc. Water & Extras	2700 kg	2850 kg

# TECHNICAL DATA SHEET – CW-80 WITH MULTI-MAGIC CONTROLS

## CW-80 IEC HIGH CAPACITY FANS

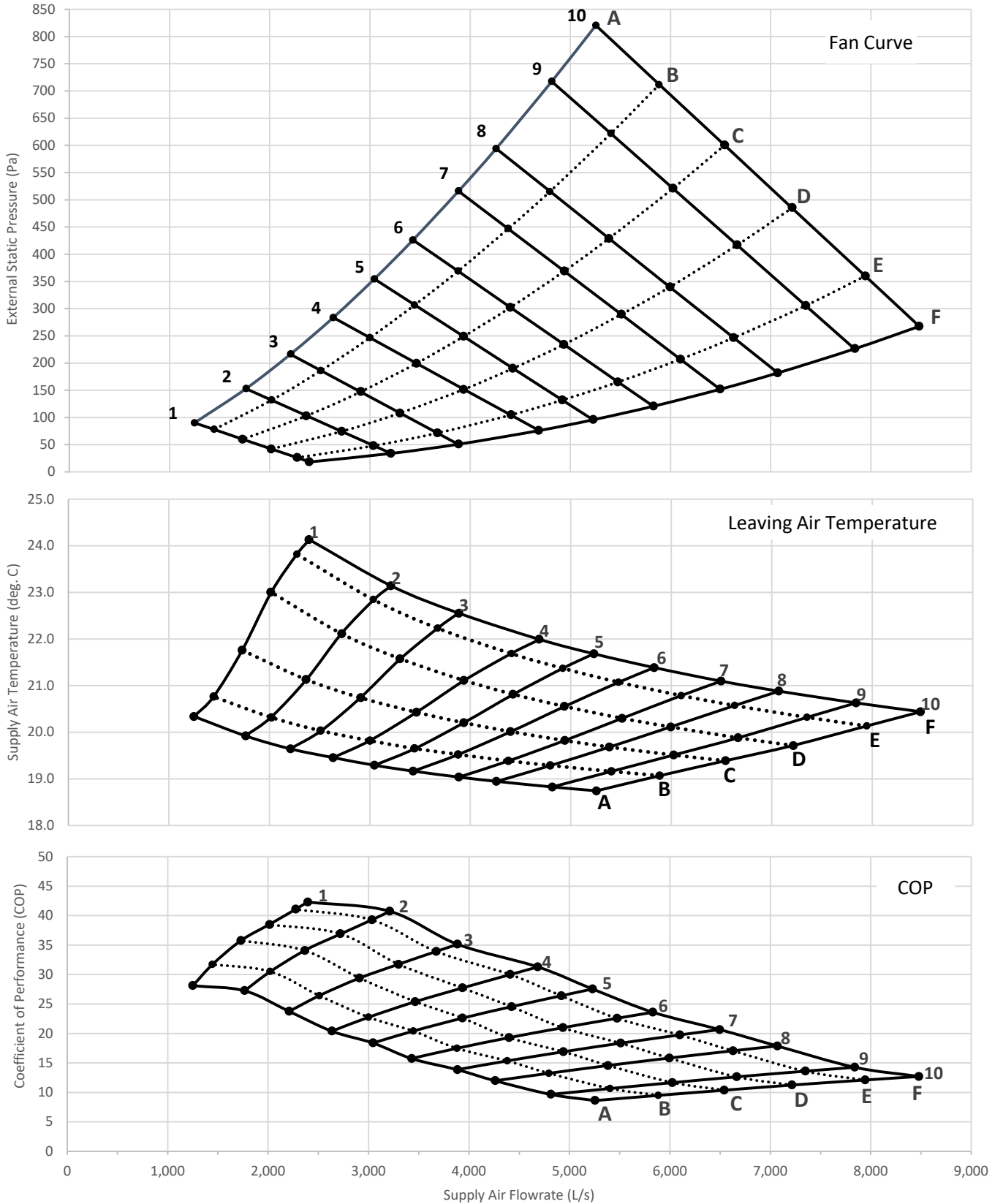

# TECHNICAL DATA SHEET – CW-80 WITH MULTI-MAGIC CONTROLS

## CW-80 SUPERCOOL HIGH CAPACITY FANS

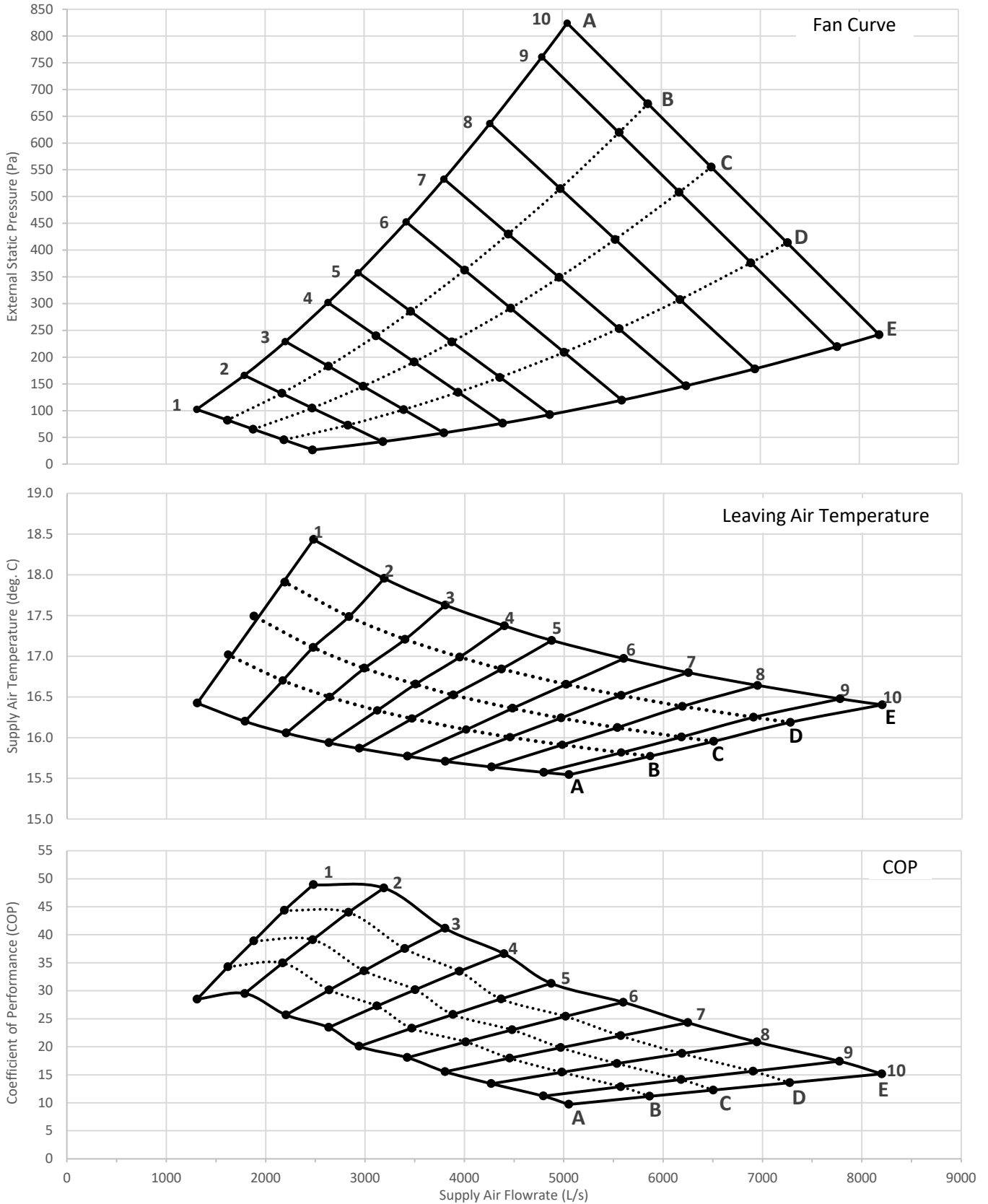

## TECHNICAL DATA SHEET – CW-80 WITH MULTI-MAGIC CONTROLS

CW-80 IEC HIGH CAPACITY SPEED 10 PERFORMANCE SUMMARY*						
	A	B	C	D	E	F
EXTERNAL STATIC PRESSURE (Pa)	820	710	600	485	360	270
SUPPLY AIR FLOWRATE (L/s)	5300	5900	6500	7200	7900	8500
SUPPLY AIR FLOWRATE (m <sup>3</sup> /h)	19,100	21,200	23,400	25,900	28,400	30,600
EXHAUST AIR FLOWRATE (L/s)	5100	5100	5100	5000	4900	4700
EXHAUST AIR FLOWRATE (m <sup>3</sup> /h)	18,400	18,400	18,400	18,000	17,600	16,900
IEC LEAVING AIR TEMPERATURE (°C)	18.7	19.1	19.4	19.7	20.1	20.4
STANDALONE COOLING CAPACITY (kW)	56	60	64	68	71	73
PRE-COOLING CAPACITY (kW)	124	135	146	159	171	181
INPUT POWER (kW)	14.2	14.2	14.2	14.2	14.2	14.2
STANDALONE COP	4	4	5	5	5	5
PRE-COOLING COP	9	10	10	11	12	13
WATER CONSUMPTION (L/hr)	235	245	255	265	270	275

CW-80 SUPERCOOL HIGH CAPACITY SPEED 10 PERFORMANCE SUMMARY*					
	A	B	C	D	E
EXTERNAL STATIC PRESSURE (Pa)	825	675	555	415	240
SUPPLY AIR FLOWRATE (L/s)	5000	5900	6500	7300	8200
SUPPLY AIR FLOWRATE (m <sup>3</sup> /h)	18,000	21,200	23,400	26,300	29,500
EXHAUST AIR FLOWRATE (L/s)	5100	5100	5000	4900	4800
EXHAUST AIR FLOWRATE (m <sup>3</sup> /h)	18,400	18,400	18,000	17,600	17,300
IEC SUPPLY TEMPERATURE (°C)	18.6	19.1	19.4	19.8	20.2
IDEC LEAVING AIR TEMPERATURE (°C)	15.5	15.8	16.0	16.2	16.4
STANDALONE COOLING CAPACITY (kW)	73	84	91	101	111
PRE-COOLING CAPACITY (kW)	136	159	173	193	214
INPUT POWER (kW)	14.2	14.2	14.2	14.2	14.2
STANDALONE COP	5	6	6	7	8
PRE-COOLING COP	10	11	12	14	15
WATER CONSUMPTION (L/hr)	265	280	295	310	335

\* Leaving Air Temperatures, Cooling Capacities and Water Consumption valid at design condition of: 38 °C dry-bulb, 21 °C wet-bulb, 27.4 °C relief temperatures

INPUT POWER (kW)					
SPEED	CW-80 IEC HIGH CAPACITY	CW-80 SUPERCOOL HIGH CAPACITY	SPEED	CW-80 IEC HIGH CAPACITY	CW-80 SUPERCOOL HIGH CAPACITY
10	14.2	14.2	5	3.8	3.9
9	11.6	11.6	4	2.9	3.0
8	8.2	8.6	3	2.1	2.3
7	6.4	6.6	2	1.4	1.6
6	5.0	5.1	1	1.0	1.2

## TECHNICAL DATA SHEET – CW-80 WITH MULTI-MAGIC CONTROLS

### OPTIONS, FEATURES & ACCESSORIES

Multi-Magic® coolers are supplied with a series of interface terminals inside the electrical enclosure for use with additional accessories.

ITEM	ID	TYPE
MODBUS	+	RS-485 MODBUS Communication for Wall Controller or 3rd Party Master
	-	
	GND	
POWER SUPPLY	24 VDC	DC Power Supply for Wall Controller, Sensors or BMS
	0 VDC	
MULTI-MAGIC SENSORS (sold separately)	S1	Flexible Sensor Inputs for use with Optional Sensors. See next page.
	S2	
	S3	
	S4	
	S5	
	S6	
FAN STATUS	FAN STS	Fan Run Output. Relay Output Dry Contact, Adjustable Timer
	FAN COM	
FIRE	FIRE	Fire Terminals. Bridge to Run.
	FIRE	

Multi-Magic® coolers can be controlled via 4 different methods

#### OPTION 1: BUILDING MANAGEMENT SYSTEM (BMS)

Multi-Magic® coolers are supplied with a series of low voltage BMS Interface Terminals to allow external devices, such as 3rd party controllers, to control the basic functions of the cooler.

ITEM	ID	TYPE
BMS	IEC	Digital Input Dry Contact
	DEC	Digital Input Dry Contact
	SPD	Supply Fan Speed: Analogue Input 0-10Vdc equates to Speeds 0 to 10
	ERR	Error: Relay Output Dry Contact. Configurable NO/NC
	GND	GND

#### OPTION 2: MULTI-MAGIC® WALL CONTROLLER

(sold separately)

- MODBUS RS-485 to control up to 15 Devices
- Temperature & Relative Humidity Sensors
- Manual IEC, Supercool & Fan Speed Control
- Thermostatic Speed Control
- Supercool Humidity Setpoint
- 7-Day Thermostatic Program
- Room Sensor Averaging
- Ambient Condition Monitoring
- Min & Max Fan Speed Limits
- Screen Security Lock
- Auto-Restart Function
- Device Fault History
- English, Spanish, French, Italian, Portuguese



#### OPTION 3: RS-485 MODBUS PRIMARY

Modbus Registers are available for controlling and monitoring the basic functions of the connected coolers.

REGISTER	TYPE	DETAILS	
COMMANDS			
9200	UINT	Bit 0	IEC Enable
		Bit 1	DEC Enable
		Bit 2	Fault Reset
		Bit 3	Manual Drain
9201	UINT	0-1000	Supply Fan Speed (0-100%)
STATUS			
9205	UINT	Bit 0	Fault State
		Bit 1	Low Probe WET
		Bit 2	High Probe WET
		Bit 3	Inlet Solenoid Valve OPEN
		Bit 4	Drain Valve OPEN
		Bit 5	Indirect Pump RUNNING
		Bit 6	Direct Pump RUNNING
		Bit 7	Chlorinator RUNNING
9206	UINT	0-100	Supply Fan Speed (0-100%)
9207	UINT	0-6615	Water Salinity Level
9208	UINT	0-100	Chlorinator Output (%)
9209	UINT		Fault Code
9210 to 9215	INT	S1 to S6	Sensor Values depend on sensor type Temperature °C /10 Relative Humidity %/10 Pressure Pa /100
9216	UNIT	0-100	Exhaust Fan Speed (0-100%)

#### OPTION 4: BACNET MS/TP OR BACNET IP

BACnet objects are available for controlling and monitoring the basic functions of the connected coolers.

OBJECT	DETAILS
COMMANDS	
CMD_IEC	IEC Enable
CMD_DEC	DEC Enable
CMD_Spd	0 to 10 Fan Speed
CMD_Drain	Manual Drain
BCN_CMD_ON_OFF	Cooler Run
CMD_FaultReset	Reset Fault Codes
STATUS	
STSIEC	IEC Pump RUNNING
STSDEC	DEC Pump RUNNING
STSERROR	Fault
STSLowProbe	Low Probe WET
STSHighProbe	High Probe WET
STSSolenoid	Inlet Solenoid OPEN
STSDrain	Drain Valve OPEN
STSChlorinator	Chlorinator RUNNING
STSSupplyFSpd	Supply Fan Speed Range 0 to 10
STSSalinity	Water Salinity Level (uS/cm)
STSFaultCode	Fault Code.
STSExhaustFSpd	Supply Fan Speed (Vdc)
STSensor1	Sensor Values depend on sensor type Ambient Sensor Temperature -40 to 70°C Room & Duct Sensor Temperature 0 to 40°C Relative Humidity 0 to 100 % Pressure Sensor 0 to 500 Pa
STSensor2	
STSensor3	
STSensor4	
STSensor5	
STSensor6	

## TECHNICAL DATA SHEET – CW-80 WITH MULTI-MAGIC CONTROLS

### OPTIONAL SENSORS ACCESSORIES

(sold separately)

For all sensors:

Operating Voltage DC 24V

Signal Output DC 0...10 V

Accuracy at 23°C and 50% r.h.

Temperature:  $\pm 0.3K$

Relative Humidity:  $\pm 3\%$  r.h.

Pressure  $\pm 1\%$

Each CW-80 cooler had six sensors inputs, configured in pairs, for use with the following optional sensors. All sensor values are readable by Building Management Systems (Low Voltage, Modbus or BACnet).

#### ROOM TEMPERATURE & RELATIVE HUMIDITY SENSOR

Temperature Range  
0...+50°C

Relative Humidity Range  
0...100% r.h.

IP30



When used in conjunction with the Multi-Magic® Wall Controller:

- Allows the Wall Controller to be located safely away from the conditioned space. Wall Controller sensor values are disabled and only Room Sensor used for setpoint control.
- Multiple Room Sensor values from multiple coolers can be averaged together to provide overall temperature and relative humidity values for larger spaces.

#### AMBIENT TEMPERATURE & RELATIVE HUMIDITY SENSOR

Temperature Range  
-40...+70°C

Relative Humidity Range  
0...100% r.h.

Radiation Shield  
IP65



When used in conjunction with the Multi-Magic® Wall Controller:

- Ambient Condition Monitoring mode uses advanced formulas to calculate a predicted supply temperature. Coolers are disabled if the predicted supply temperature is greater than the current room temperature.
- Particularly suitable for applications which require room temperatures less than 20 °C.

#### DUCT TEMPERATURE & RELATIVE HUMIDITY SENSOR

Temperature Range  
0...+50°C

Relative Humidity Range  
0...100% r.h.

IP54

Probe length inside duct min.  
90mm, max 150mm



- Can be used by Building Management Systems (Low Voltage, Modbus or BACnet) to monitor cooler supply air conditions.

#### DIFFERENTIAL PRESSURE SENSOR

Pressure Range  
0...500 Pa

IP66

LCD Display

Includes Static Pressure Tip  
250mm insertion depth.

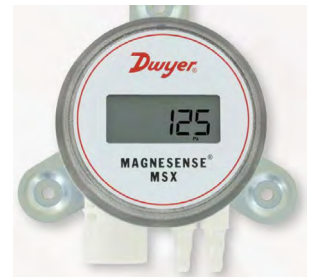

- Can be used by Building Management Systems (Low Voltage, Modbus or BACnet) to monitor pressure drops.