

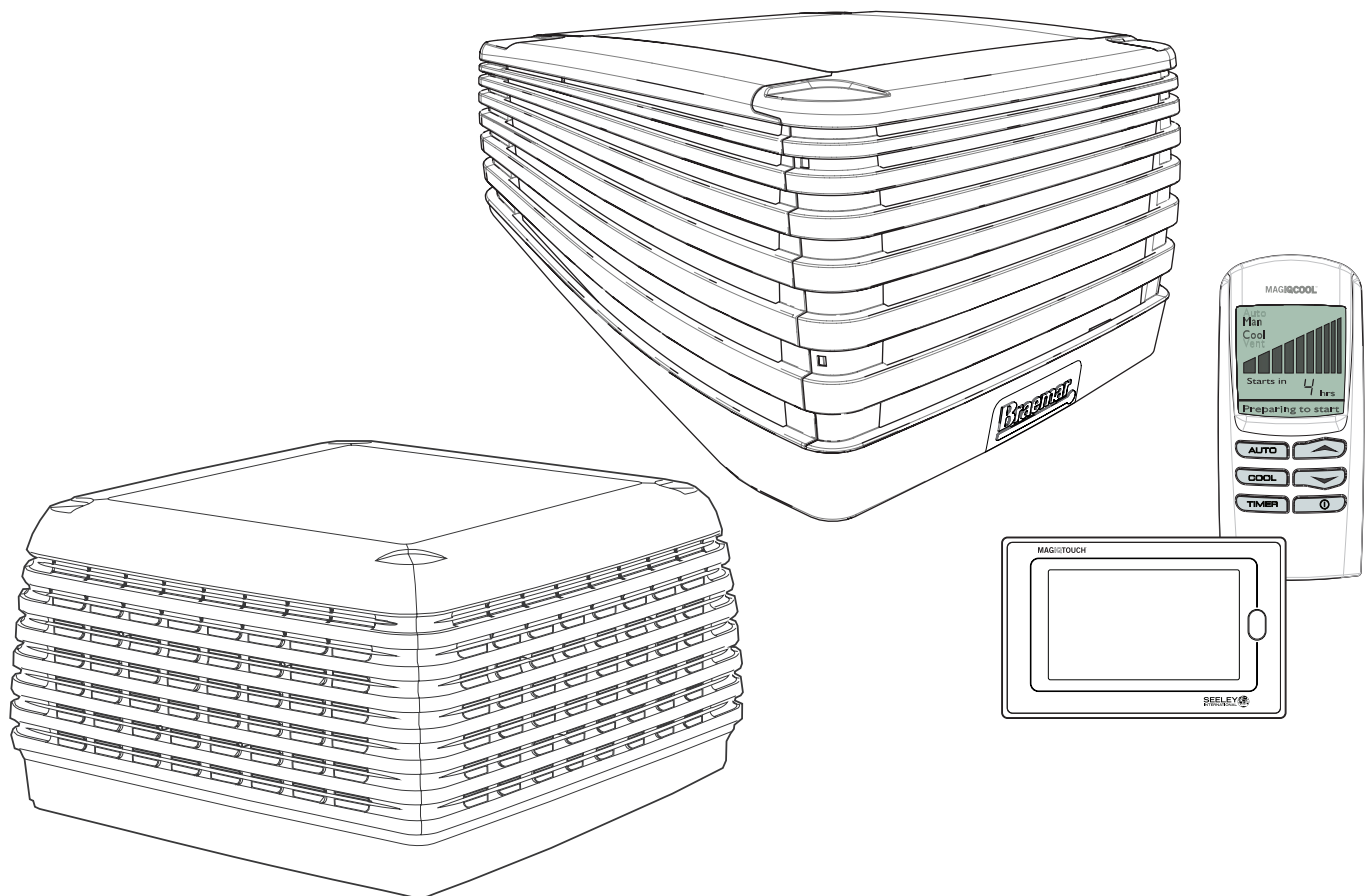

# INSTALLATION MANUAL

BMQ / CPQ / LCQ / LCS / TBQ / TBS /  
LPQI / TBQI / TBSI / LCQV / LPQV / TBQV / TBSV  
Evaporative Coolers





# TABLE OF CONTENTS

## SAFETY

Important Safety Instructions	2
For Australian Bushfire Prone Areas	2
Employer and Employee Responsibilities	2
Installer and Maintenance Contractors - Risk Assessment	2
Some Points to Consider	2
Other Important Requirements	3

## QUICK GUIDE

4

## INSTALLATION INSTRUCTIONS

Cooler Location	6
Access For Servicing And Maintenance	6
Removing the Venturi	6
Removing the Transition - CPQ, LCQ, TBQ, TBS, BMQ, TBQI, TBSI, LCQV, TBQV & TBSV	7
Removing the Transition - LPQI & LPQV	7
Preparing the Dropper	8
Mounting the Dropper - CPQ, LCQ, TBQ, TBS, BMQ, TBQI, TBSI, LCQV, TBQV & TBSV	8
Securing Dropper & Transition - CPQ, LCQ, TBQ, TBS, BMQ, TBQI, TBSI, LCQV, TBQV & TBSV	9
Mounting the Dropper - LPQI & LPQV	9
Securing the Dropper and Transition - LPQI & LPQV	10
Weatherseal - LPQI & LPQV	11
Weatherseal - CPQ, LCQ, TBQ, TBS, BMQ, TBQI, TBSI, LCQV, TBQV & TBSV	11
Conveying the Cooler to the Roof	12
Mounting the Cooler	12
Cable Installation	13
Installing the Venturi / Fan Assembly - CPQ, LCQ, TBQ, TBS, BMQ, TBQI, TBSI, LCQV, TBQV & TBSV	14
Installing the Venturi / Fan Assembly - LPQI & LPQV	14

## WATER REQUIREMENTS

Installing the Float Valve - LPQI & LPQV	15
Installing the Float Valve - CPQ, LCQ, TBQ, TBS, BMQ, TBQI, TBSI, LCQV, TBQV & TBSV	16
Installing the Inlet Solenoid - CPQ, LCQ, TBQ, TBS, BMQ, TBQI, TBSI, LCQV, TBQV & TBSV	16
Installing the Inlet Solenoid - LPQI & LPQV	17
Installing the Water Sensor	17
Mains Water Connection	18
Installing the Drain Valve	18
Bleed Funnel	19

## ELECTRICAL REQUIREMENTS

Electrical Connection	20
Multiple Cooler Installations	21

## CONNECTING THE WATER PUMP

22

## CONNECTING THE MAGIQTOUCH /MAGIQCOOL CONTROLLER

22

## MAGIQCOOL CONTROLLER DISPLAY INFORMATION

23

## MAGIQCOOL WALL CONTROL DISPLAYS “SERVICE”

23

## MAGIQTOUCH CONTROLLER DISPLAY INFORMATION

23

## CHANGING THE WATER MANAGEMENT METHOD FOR THE MAGIQCOOL CONTROL

23

## SETTING THE WATER LEVEL

24

## COMMISSIONING THE COOLER

Test Operation	25
CPQ, LCQ, TBQ, TBS, BMQ, TBQI, TBSI, LCQV, TBQV & TBSV models	
Refitting the Pad Frames	25
Supercool Pad Positions	25
LPQI & LPQV Models	26
Removing the Pad Frames	26
Refitting the Pad Frames	26

## TESTING THE PUMP

27

## TESTING THE DRAIN VALVE

27

## COMMISSIONING COMPLETION CHECKLIST

27

## ADJUSTING COOLER SETTINGS

28

## FAULT CODES INDICATED BY LED's ON THE COOLER ELECTRONICS MODULE

28

## TROUBLE SHOOTING

29

**WARNING! Failure to install and commission the product in compliance with these instructions, or failure to do the job properly and competently, may void the customer's warranty. Further, it could expose the Installer and/or the Retailer to serious liability.**

## IMPORTANT SAFETY INSTRUCTIONS

### READ AND SAVE THESE INSTRUCTIONS FOR FUTURE REFERENCE.

Means for all pole disconnection must be incorporated in the fixed wiring in accordance with the wiring rules.

If the supply cord is damaged, it must be replaced by the manufacturer, its service agent or similarly qualified persons in order to avoid a hazard.

**The following specifications for the cooler water supply are required:**

**Min Water Pressure:** 100kPa (15psi)

**Max Water Pressure:** 800kPa (115psi)

New hose sets supplied with the appliance are to be used and old hose-sets should not be re-used.

### WARNING - TO REDUCE THE RISK OF FIRE, ELECTRIC SHOCK, OR INJURY TO PERSONS, OBSERVE THE FOLLOWING:

- a) Installation work and electrical wiring must be done by qualified person(s) in accordance with all applicable codes and standards, including fire-rated construction.
- b) When cutting or drilling into wall or ceiling, do not damage electrical wiring and other hidden utilities.
- c) Ducted fans must always be vented to the outdoors
- d) Do not use this fan with any solid-state speed control device.
- e) Do not use replacement parts that have not been recommended by the manufacturer (e.g. parts made at home using a 3D printer).

### FOR AUSTRALIAN BUSHFIRE PRONE AREAS MODELS:

LCQ, LCS, LCQV, LCSV, BMQ, CPQ

### THE BELOW WARNINGS APPLY

**WARNING:** If this evaporative cooler is installed on a BAL-12.5 or BAL-19 rated property, the following additional components are also required.

- A non-combustible butterfly closer with a maximum aperture of 3mm installed inside the dropper duct as close as practicable to the roof lining

### AND

- Pad frames fitted with non-combustible, corrosion-resistant mesh ember guards with a maximum aperture of 2mm.

The above components are available through Seeley International Sales, Australia.

In addition, the dropper duct and flashings shall be non-combustible and shall be adequately sealed using a non-combustible sealant to prevent gaps greater than 3mm.

This cooler is **NOT APPROVED** for installation on a BAL-29, BAL- 40 or a BAL-FZ rated property.

**WARNING: MODEL LPQV is NOT APPROVED for installation into any bushfire zoned area/property (BAL-12.5 to BAL-29).**

### EMPLOYER AND EMPLOYEE RESPONSIBILITIES

The installation and maintenance of evaporative coolers at height has the potential to create Occupational Health and Safety issues for those involved. Installers are advised to ensure they are familiar with the relevant State and Federal legislation, such as Acts, Regulations, approved Codes of Practice and Australian Standards, which offer practical guidance on these health and safety issues. Compliance with these regulations will require appropriate work practices, equipment, training and qualifications of workers.

Seeley International provides the following information as a guide to contractors and employees to assist in minimising risk whilst working at height.

### INSTALLER AND MAINTENANCE CONTRACTORS - RISK ASSESSMENT

A risk assessment of all hazardous tasks is required under legislation. A risk assessment is an essential element that should be conducted before the commencement of work, to identify and eliminate the risk of falls or to minimise these risks by implementing control measures. There is no need for this to be a complicated process, it just is a matter of looking at the job to be done and considering what action(s) are necessary so the person doing the job does not injure themselves.

This should be considered in terms of:

- What are the chances of an incident happening?
- What could the possible consequence be?
- What can you do to reduce, or better still, completely get rid of the risk?

### SOME POINTS TO CONSIDER

- What is the best and safest access to the roof and working areas?
- If a worker is alone, who knows they are there and if they get into difficulty, how can they summon help? (Call someone on the ground? Mobile phone? Etc.)
- What condition is the roof in? Should the trusses, underside or surface be checked?
- Does the worker have appropriate foot wear? (Flat sole jogger type is advisable.)
- Are all power cables / extension leads safe and appropriately rated?
- Are all ladders, tools and equipment suitable in good condition?
- Where ladders are to be used, is there a firm, stable base for them to stand on? Can they be tied or secured in some way at the top? Is the top of the ladder clear of electricity supply cables?
- Is there a roof anchor to attach a harness and lanyard to? If so, instruction should be issued for the use of an approved harness or only suitably trained people used.
- Are all tools and materials being used, prevented from slipping and falling onto a person at ground level? Is the area below the work area suitably protected to prevent persons walking in this area?
- Does the work schedule take into account weather conditions, allowing for work to be suspended in high winds, thunder storms/lightning or other types of weather giving wet, slippery surfaces?
- Is there an on-going safety check system of harnesses, ropes, ladders and access/lifting equipment and where they exist on roofs, anchor points before the commencement of work?



## **IMPORTANT SAFETY INSTRUCTIONS**

- Is there a system which prevents employees from working on roofs if they are unwell or under the influence of drugs or alcohol?
- Are there any special conditions to consider i.e. excessive roof pitch, limited ground area, fragile roof, electrical power lines?

## **OTHER IMPORTANT REQUIREMENTS**

- Never force parts to fit because all parts are designed to fit together easily without undue force.
- Never drill holes in the tank of the cooler.
- Check the proposed cooler location, to ensure that it is structurally capable of supporting the weight of the cooler, or provide an adequate alternate load bearing structure.

Ensure the installation complies with all local and national regulations with regards to electrical, plumbing and bushfire construction requirements.

## QUICK GUIDE

### Step 1

#### SAFETY

Read & understand the safety section.

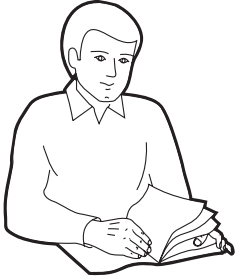

Page 2

### Step 2

#### COOLER LOCATION

Check cooler location. Consider regulations. Discuss with customer.

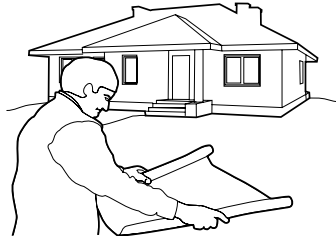

Page 6

### Step 3

#### REMOVE VENTURI

Press the clip or remove the screws on both sides of the venturi to release.

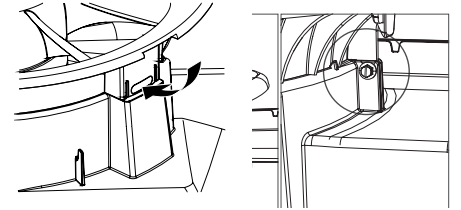

Page 6

### Step 7

#### SECURE DROPPER & TRANSITION

Use the TEK screws provided. Break the transport clips for the Weatherseal.

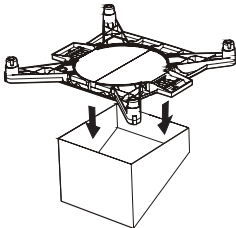

Page 9

### Step 8

#### CHECK WEATHERSEAL

Check operation of the Weatherseal. Ensure Weatherseal moves freely.

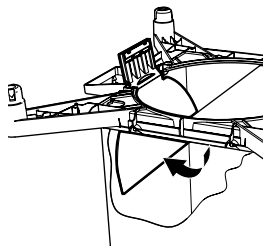

Page 11

### Step 9

#### CONVEY COOLER TO ROOF

Always use 2 persons to position the cooler when handling manually.

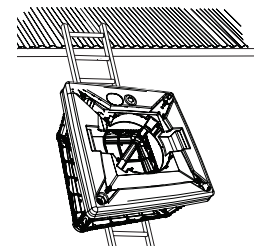

Page 12

### Step 13

#### INSTALL FLOAT VALVE

Assemble the float valve to the cooler. Ensure all washers and o-rings are in place. No thread tape is required.

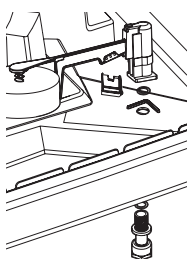

Page 15

### Step 14

#### INSTALL INLET SOLENOID

Use the supplied hose set and fittings. Note the water flow direction marking on the solenoid.

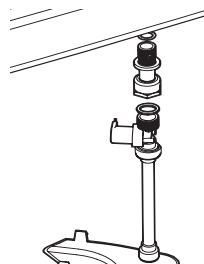

Page 16

### Step 15

#### INSTALL WATER SENSOR

Ensure the clip is fully engaged.

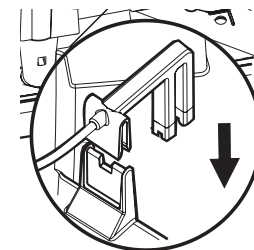

Page 17

### Step 19

#### MOUNT AND CONNECT THE CONTROLLER

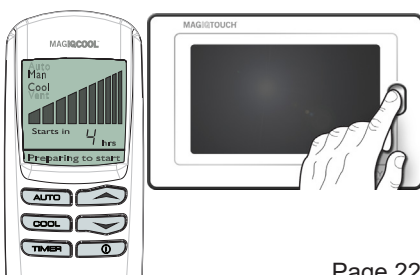

Page 22

### Step 20

#### SET THE WATER LEVEL

Turn on the mains water and adjust the float to allow water to fill to the required level.

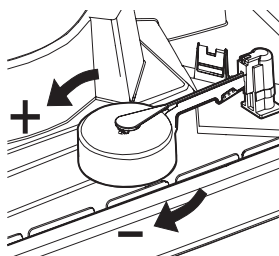

Page 24

### Step 21

#### COMMISSIONING THE COOLER

Switch the mains power on and test run the cooler.

Page 25

## QUICK GUIDE cont.

### Step 4

#### REMOVE TRANSITION

Press the clips inwards to release the transition from the tank.

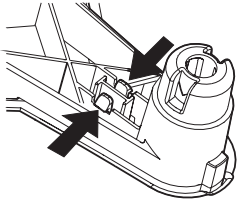

Page 7

### Step 5

#### PREPARE THE DROPPER

Cut hole & fit the grommet in the dropper for power and control cables.

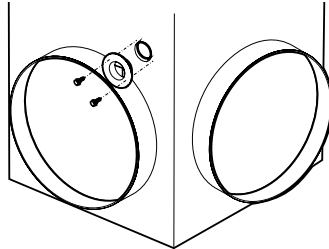

Page 8

### Step 6

#### MOUNT DROPPER

Position, level and secure the dropper. Flash the dropper to prevent water ingress into the roof cavity.

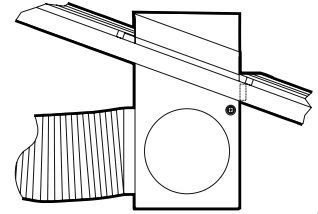

Page 8

### Step 10

#### MOUNT THE COOLER

Lower the cooler onto the transition.

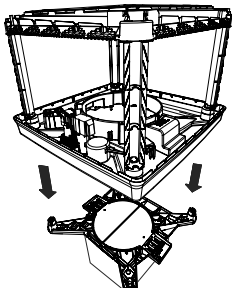

Page 12

### Step 11

#### CABLE INSTALLATION

Run the power and control cable down the dropper and out through the grommet.

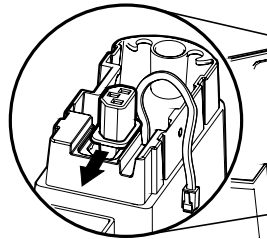

Page 13

### Step 12

#### INSTALL VENTURI / FAN

Ensure the venturi is fully located into the tank and the motor lead is not caught or pinched.

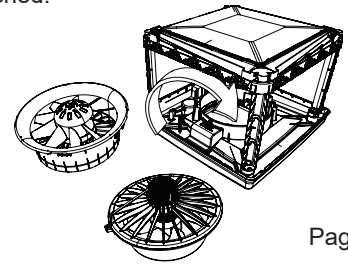

Page 14

### Step 16

#### INSTALL DRAIN VALVE

Never drain waste water directly onto the roof. Be sure to use supplied 'O' Rings and fittings.

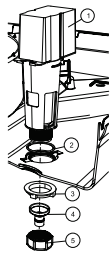

Page 18

### Step 17

#### LOCAL REGULATIONS

Read and adhere to local electrical and plumbing rules and regulations.

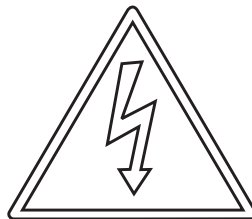

Page 20

### Step 18

#### ELECTRICAL CONNECTIONS

Connect the cooler components to the electronics module. Plug the mains cable into the electronics module.

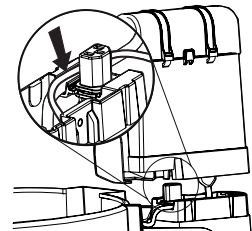

Page 20

### Step 22

#### FINAL CHECK

Complete the commissioning checklist at the end of this document.



Page 27

### Step 23

#### CLEAN UP

Clean up the site!



Page 27

### Step 24

#### CUSTOMER HANDOVER

Show the customer how to operate the cooler. Give them both the controller and cooler owner's manual. Explain maintenance requirements.



Page 27

# INSTALLATION INSTRUCTIONS

## COOLER LOCATION

Check proposed cooler location to ensure it is structurally capable of supporting the weight of the cooler. If the roof is structurally inadequate, provide an alternate load bearing structure.

The ideal location for the cooler is in a central position on the roof (away from sleeping areas and where people spend most of their time) so that the duct runs are of approximately the same length. Carefully consider neighbouring residences and noise levels when locating the cooler, if necessary talk to the customer and the neighbour before carrying out the installation.

Always locate the cooler where it will receive adequate fresh air and not in a recess where it may be starved for air or where the air is polluted.

### Ensure location is a minimum of:

- 3m (10') from a solid fuel heater flue,
- 1.5m (5') from a gas flue,
- 1.0m (3.5') away from adjacent solar panels or similar roof mounted fixtures,
- 5m (17') from a sewer vent, and
- 600mm (2') from a wall.

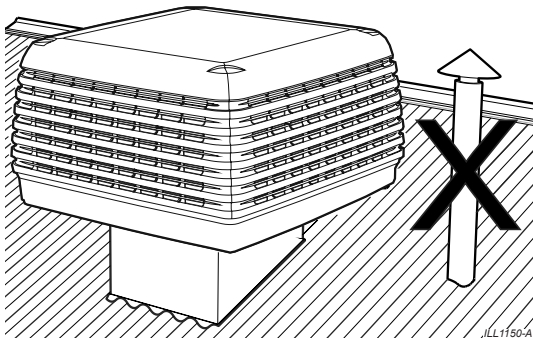

- The cooler must be mounted at least 3m (10') (preferably 5m (17')) away from any TV antenna or antenna cables. Make sure the cooler is not between the antenna and the transmission tower that is providing the television signal to the home.

Allow adequate access to and around the cooler for maintenance. Provision must be made for access to electricity, water supplies and drains.

**Note!** Do you need to discuss the installation of items like safety anchor points with the customer?

## ACCESS FOR SERVICING AND MAINTENANCE

The cooler should be installed in a position that allows adequate access for installation, and future maintenance and servicing activities. This should comply with installation guidelines and any local, State and National regulations.

Consider the following for installation location:-

- Which has clear access to and around the cooler
- Which is clear of fixtures in line with below clearances
- Which is clear of fall edges (> 3m or 10' away)
- Which is structurally capable of supporting the weight of the cooler and service technicians

Required clearances around the cooler for future maintenance and servicing are shown adjacent.

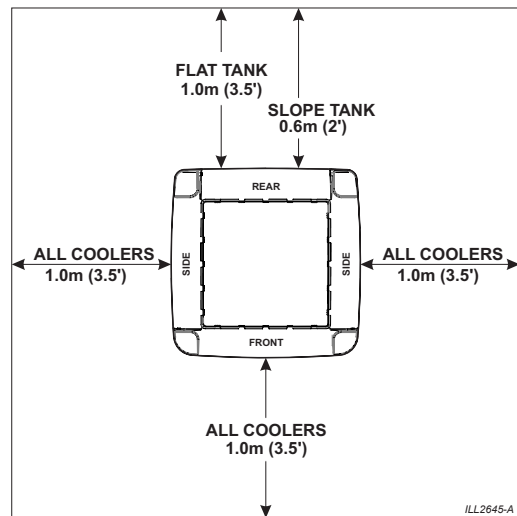

**Extra service or warranty charges may apply for the cost of any equipment or additional labour involved in accessing the cooler if these guidelines are not met.**

## REMOVING THE VENTURI

Before removing the venturi, the electronics module should be removed.

Disconnect the electronics module from the tank by removing the screw under the switch. The isolation switch cannot be activated with this screw removed. Remove the pump and motor cables from the plugs in the electronics module.

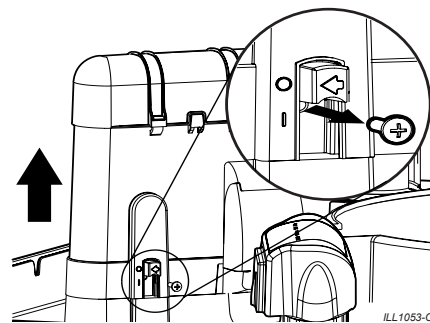

**Note!** Place the electronics module and the screw safely to one side for later use. Do not re-fit the electronics module, as the motor plug will require connection to the underside of the module when the venturi is refitted into the cooler.

For BMQ/CPQ/LCQ/TBQ/TBS models, disengage the two venturi clips as shown. For TBQI, TBSI, LPQI, LCQV, LPQV, TBQV and TBSV remove the 2 screws securing the venturi to the tank.

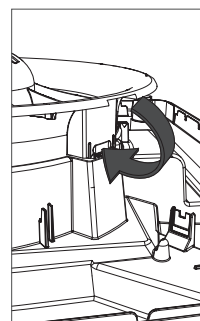

CPQ/LCQ/TBQ/TBS/  
BMQ

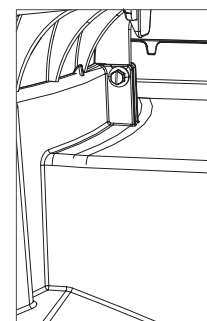

TBQI/TBSI/LCQI/LPQI/  
LPQV/TBQV/TBSV

## INSTALLATION INSTRUCTIONS cont.

Lift the venturi and fan assembly out of the cooler, taking care of the motor lead(s).

The venturi and fan assembly can be placed on to the ground until the rest of the cooler has been installed on the dropper.

### REMOVING THE TRANSITION - CPQ, LCQ, TBQ, TBS, BMQ, TBQI, TBSI, LCQV, TBQV & TBSV

Turn the cooler onto its side to remove the transition. There are clips in each of the four corners that will disengage once the transition is given a firm pull.

If any of the corners are difficult to remove, do not use excessive force. Gently squeeze the clips together and remove the transition one corner at a time.

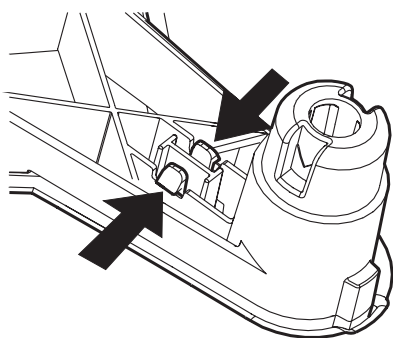

ILL1155-C

### REMOVING THE TRANSITION - LPQI & LPQV

Turn the cooler onto the rear side so that the branding badge faces upwards and the base of the transition is easily accessible.

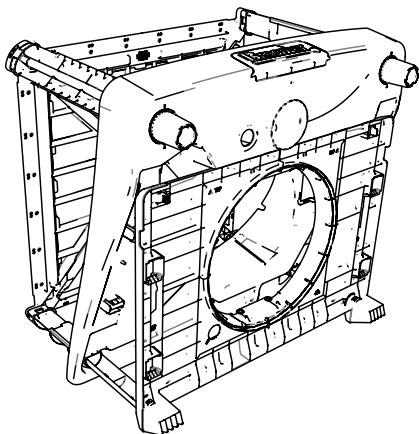

ILL2569-A

Remove the two transport feet from the base of the tank. Twist anti-clockwise to release, then pull.

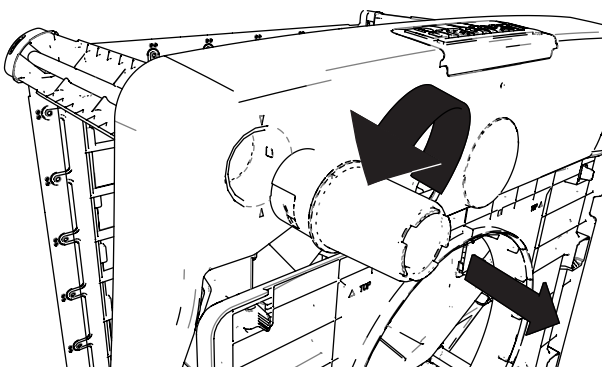

ILL2570-A

Find the 2 large clips that attach the transition directly to the tank. Disengage the clips one at a time by gently pushing the large tab until the clip disengages then giving the transition a gentle pull with the other hand. Do not use excessive force.

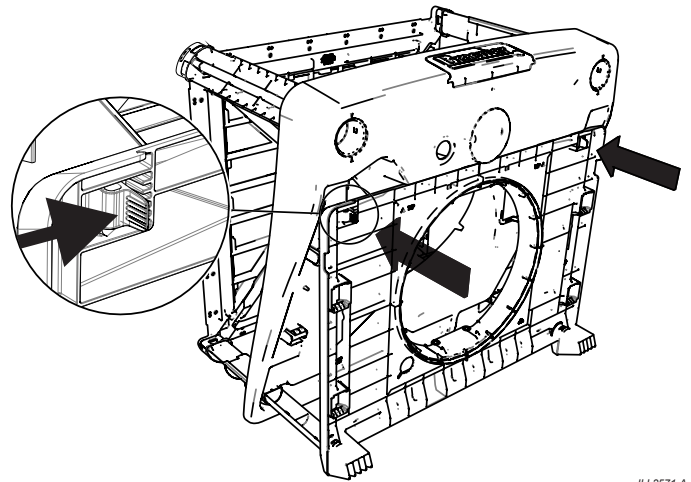

ILL2571-A

Remove the transport pillars from the tank by pulling firmly. Set the transition onto the ground with the pillars extending upwards.

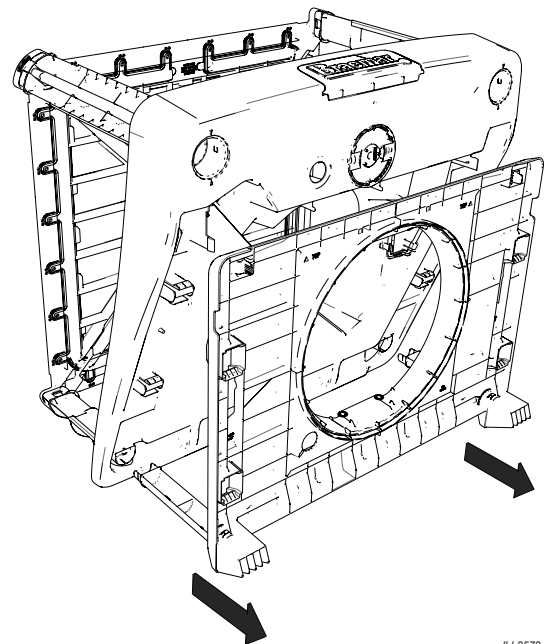

ILL2572-A

## INSTALLATION INSTRUCTIONS cont.

### REMOVING THE TRANSITION - LPQI & LPQV - cont.

Lower the cooler gently back onto the tank in preparation for transport to the roof.

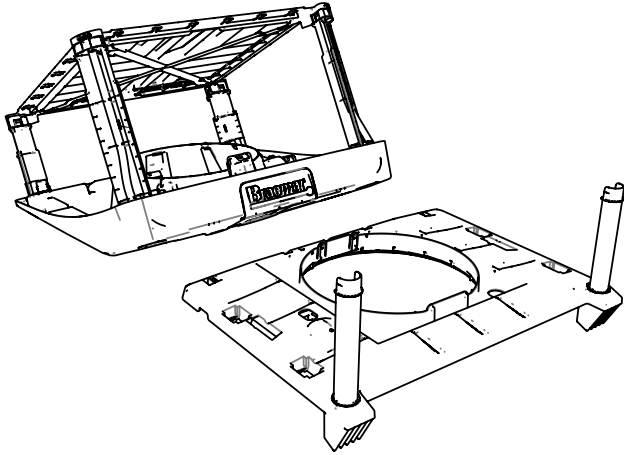

ILL2573-A

Remove the transport pillars from the transition. Twist anticlockwise to release, then pull.

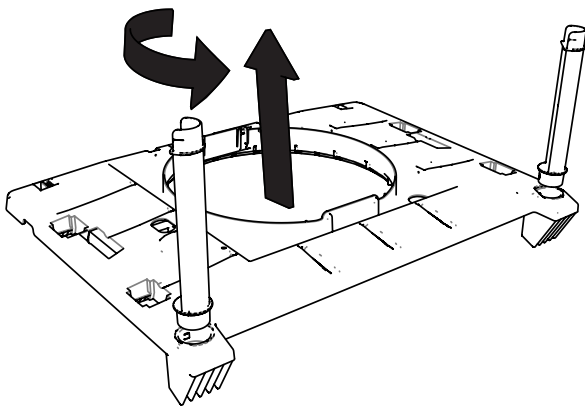

ILL2574-A

Discard of the recyclable transport feet and pillars thoughtfully.

### PREPARING THE DROPPER

The 550 x 550mm (21.7 x 21.7") dropper duct must have a raw edge or safe edge at the top. Do not fold in a flange as this may interfere with the transition and/or AutoWinterseal.

#### For Australia Only

Cut a 50mm diameter cable exit hole in the dropper then fit and screw the cable grommet into position. Locate the hole so the cables will not interfere with the operation of the AutoWinterseal.

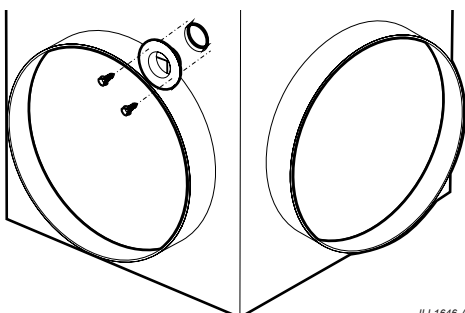

ILL1646-A

### MOUNTING THE DROPPER - CPQ, LCQ, TBQ, TBS, BMQ, TBQI, TBSI, LCQV, TBQV & TBSV

Install the dropper and securely fix it to the roof structure on 3 sides. This may require the addition of extra structural timber.

**Important!** The dropper must never sit directly on ceiling joists or beams, as this may cause noise or vibration issues, and possible ceiling damage.

Ensure the top of the dropper is level and square in all directions (use a spirit level). This helps with levelling the cooler.

The installer must ensure the dropper is suitable, and is secured adequately for wind conditions at the site. Additional restraints may be required if the cooler is more than 200mm (8") higher than the roof timbers, or design wind velocity at the site exceeds 43m/s (141fps).

In exposed or very high wind areas use 16 screws, minimum shank diameter 5.2mm (7/32") to secure the dropper. In areas subject to hurricanes/windstorms or where the cooler is located more than 8m (26') above the ground seek advice from a structural engineer.

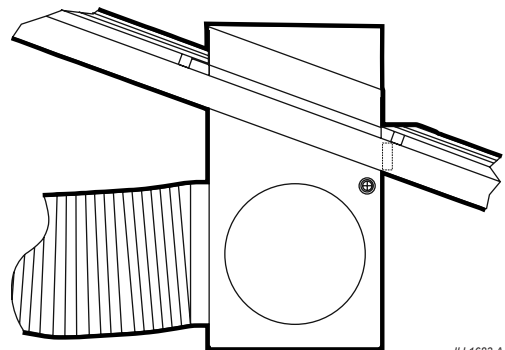

ILL1683-A

The dropper may now be flashed to the roof. Make sure there is no chance of water entering the roof space.

Ensure that it is orientated correctly, as shown by the engraved detail on the transition.

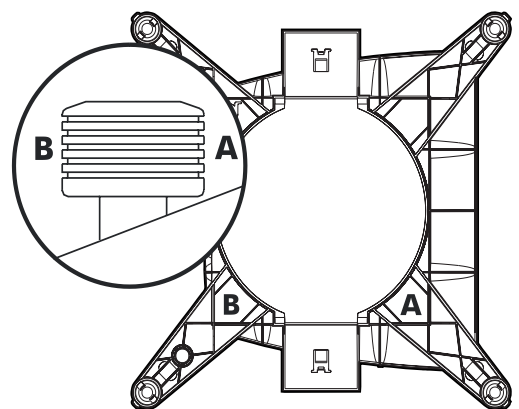

ILL969-B



## INSTALLATION INSTRUCTIONS cont.

### SECURING DROPPER & TRANSITION - CPQ, LCQ, TBQ, TBS, BMQ, TBQI, TBSI, LCQV, TBQV & TBSV

Fit the transition onto the dropper as shown.

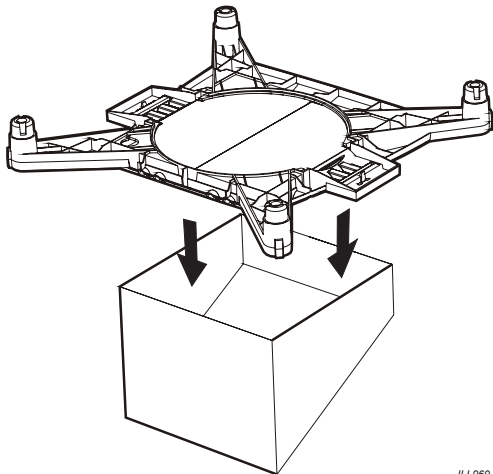

ILL969-B

Check the level of the transition on the dropper, with a spirit level placed across the flats in both directions.

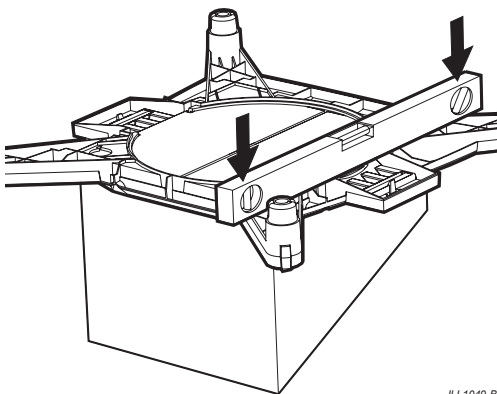

ILL1049-B

Once level, begin securing the transition to the dropper using the screws provided. There are eight 'V' notch locations for screws.

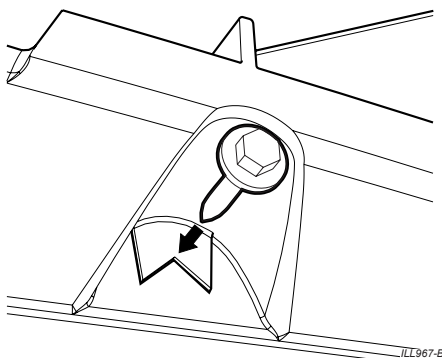

ILL967-B

Only use the screws provided. These must be used in the correct positions to prevent interference with the AutoWinterseal. All eight (8) screws must be used. Check the level periodically before driving in all the screws.

Ensure the duct insulation is firmly held against the duct connector flange on the dropper.

### MOUNTING THE DROPPER - LPQI & LPQV

The dropper must be installed at a 22.5° angle for all roof pitches. The dropper should protrude from the roof sufficient such that there is adequate space for flashing and for the drain pipe at the front of the cooler. Low profile flashing (45-50mm) will allow low profile installation of the cooler. Larger flashing will result in the unit sitting higher on the roof structure.

Important! The dropper must never sit directly on ceiling joists or beams, as this may cause noise or vibration issues, and possible ceiling damage. All installations, roof penetrations, flashing etc. must in accordance with local, state and federal regulations.

#### 22.5° Pitch Roof:

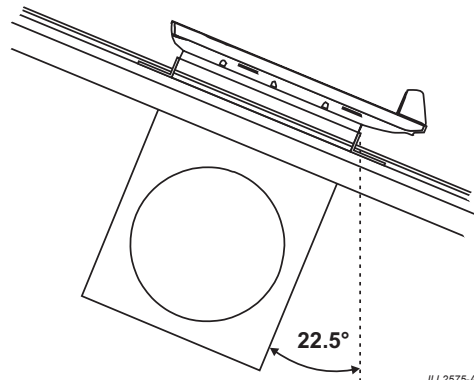

ILL2575-A

#### Greater than 22.5° Pitch Roof:

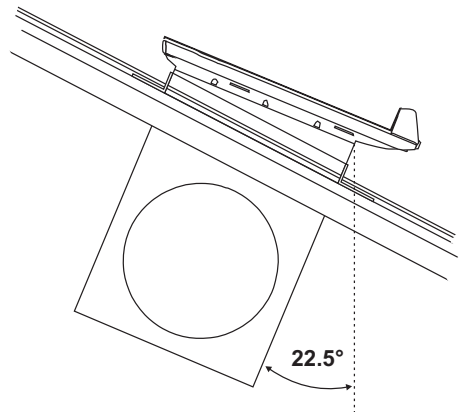

ILL2576-A

#### Less than 22.5° Pitch Roof:

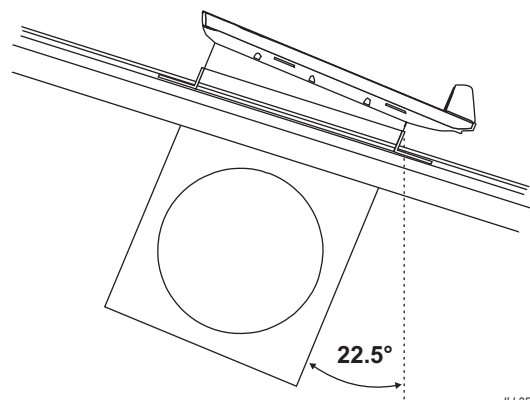

ILL2577-A



## INSTALLATION INSTRUCTIONS cont.

### EXTRA NOTES FOR LPQI & LPQV MODELS ONLY

#### INSTALLING THE SUPPORT BRACKETS

**Important!** The two (2) support brackets supplied with this LPQI cooler must be installed on the dropper before fitting the transition and cooler. Failure to do so may result in excessive stress on the cooler.

Before attaching the transition to the dropper, assemble the two (2) support brackets.

Hang the Duct Support Brackets on each side so that they rest on what will be the lower corners of the dropper.

**Note:** Keep the bubble wrap protection in place at the end of the arms to avoid injury during installation.

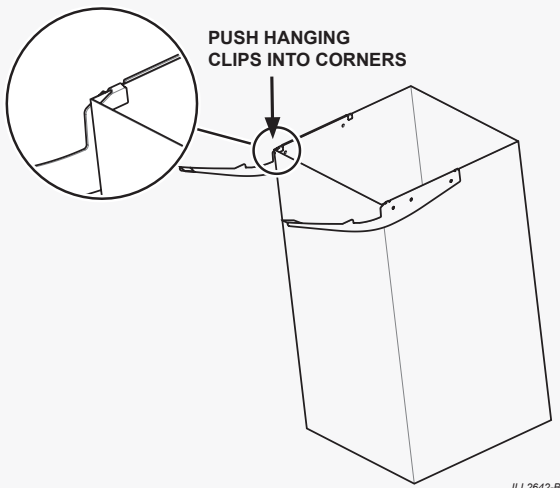

Place the transition on top of the dropper over the support brackets. Ensure the holes in the bracket align to the screw positions in the transition.

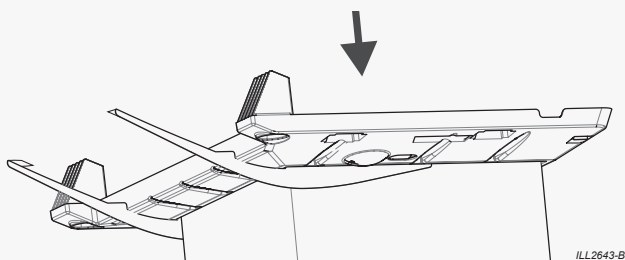

#### SECURING DROPPER & TRANSITION LPQI & LPQV

The dropper must be securely fixed to the roof structure on 3 sides. This may require the addition of extra structural timber.

The installer must ensure the dropper is suitable, and is secured adequately for wind conditions at the site. Additional restraints may be required if the cooler is more than 200mm (8") higher than the roof timbers, or design wind velocity at the site exceeds 43m/s (141fps).

In exposed or very high wind areas use 16 screws, minimum shank diameter 5.2mm (7/32") to secure the dropper. In areas subject to hurricanes/windstorms or where the cooler is located more than 8m (26') above the ground seek advice from a structural engineer.

The transition can be used with a standard spirit level to achieve the required angle.

Secure the transition (and support brackets) to the dropper using the screws provided. **NOTE:** Transition screw holes align with the support bracket holes.

**Hint:** Only 4 screws need to be fitted at this point since the transition will need to be removed later when the dropper is flashed to the roof.

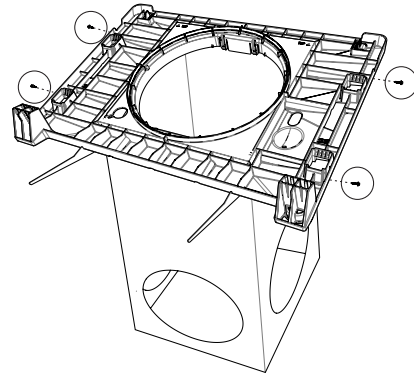

Lower the dropper and transition assembly into the prepared hole in the roof. Locate the cut-outs above the engraved text "SPIRIT LEVEL".

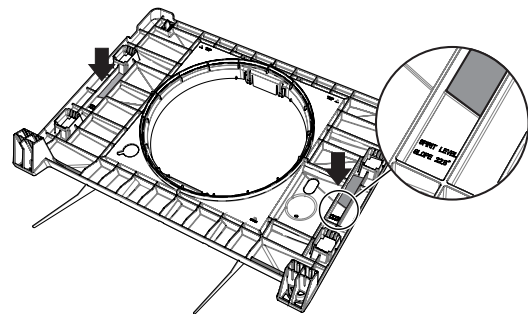

Starting on one side, insert the spirit level into the cut-out so that it rests on the edge and also on the foot of the transition. Adjust the dropper & transition until the spirit level is true. Fix this side of the dropper into the roof structure.

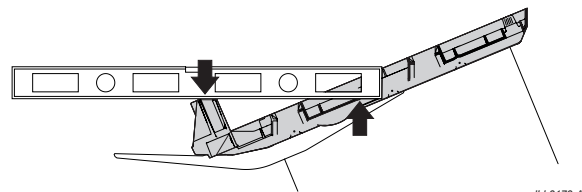

Fix other sides of the dropper in place, checking the level on all sides of the transition periodically to achieve correct angle.

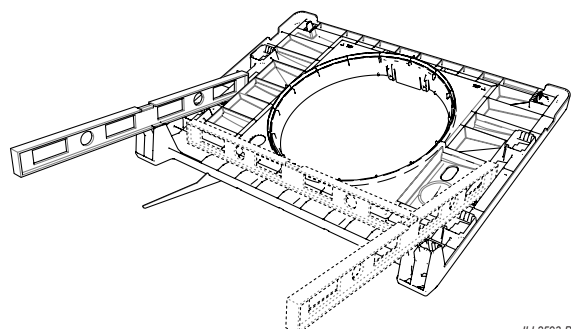

## INSTALLATION INSTRUCTIONS cont.

### SECURING DROPPER & TRANSITION LPQI & LPQV

Temporarily remove the transition, support brackets and retaining screws for later use.

The dropper may now be flashed to the roof. Make sure there is no chance of water entering the roof space. **Important:** Consider the support bracket mounting locations and ensure the flashing will not interfere.

Re-assemble the transition (and support brackets) to the dropper and use the level to confirm the angle is still correct. Begin securing the transition (and support brackets) using the screws provided.

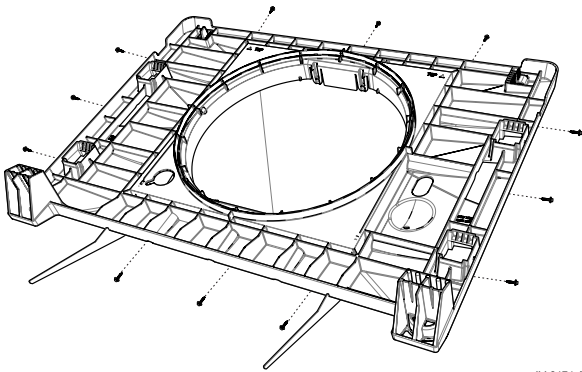

ILL3174-A

Only use the screws provided. These must be used in the correct positions to prevent interference with the AutoWinterseal. All twelve (12) screws must be used. Check the level periodically before driving in all the screws.

Ensure the duct insulation is firmly held against the duct connector flange on the dropper.

### WEATHERSEAL - LPQI & LPQV

Before installing the two (2) Weatherseal flaps, lay them side by side so that the text "THIS SIDE UP" is visible. This is the orientation in which they should be fitted to the transition.

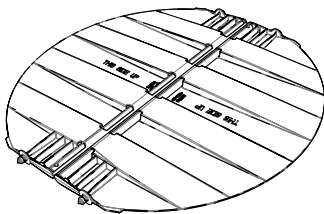

ILL2596-A

Pass the first Weatherseal flap through the transition aperture and into the dropper cavity.

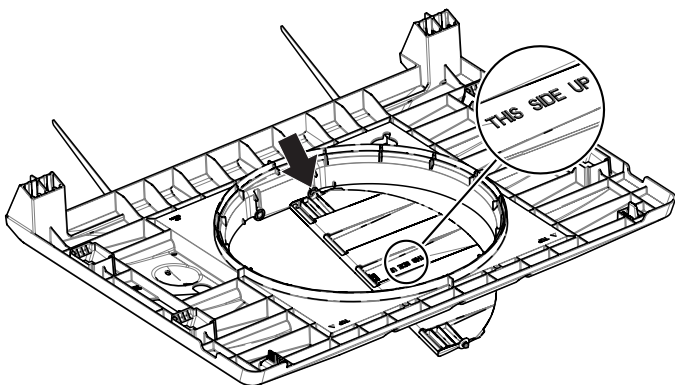

ILL2598-A

Orientate the flap so that it is in a relatively flat position and locate the first axle into the round hole on the lowest side of the transition (i.e. closest to the gutter).

Ensure the words, "THIS SIDE UP," are facing up.

Locate the second axle into the opposite hole by flexing the slotted wall back while pulling the flap axle up into place. The tracks either side of the hole will help guide the axle into the correct position.

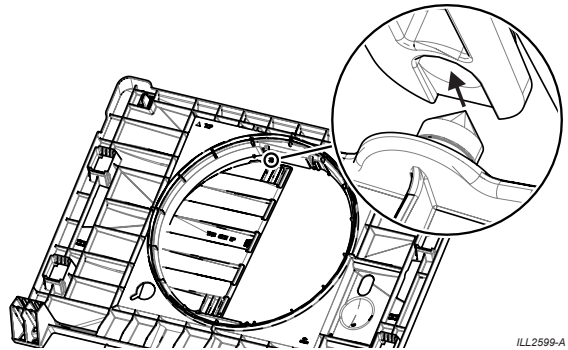

ILL2599-A

Check weatherseal operation is free by pressing on the flat face. Repeat process to install the second weather-seal flap.

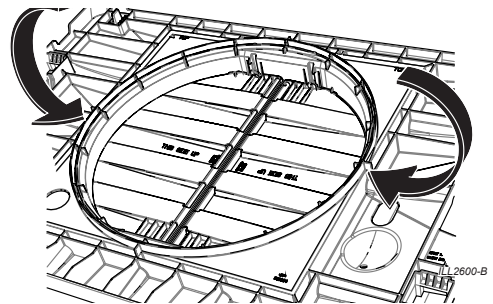

### WEATHERSEAL - CPQ, LCQ, TBQ, TBS, BMQ, TBQI, TBSI, LCQV, TBQV & TBSV

Break off both clips on the transition that retain the Weatherseal flaps. Ensure that the Weatherseal flaps open all the way and do not interfere with the dropper or any screws. The flaps should move freely through 90°.

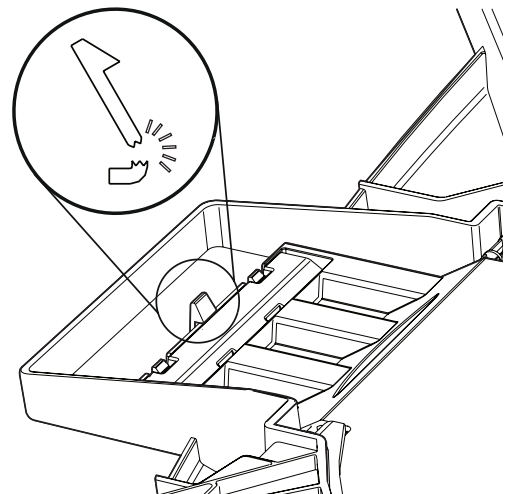

ILL983-B

## INSTALLATION INSTRUCTIONS cont.

### WEATHERSEAL - CPQ, LCQ, TBQ, TBS, BMQ, TBQI, TBSI, LCQV, TBQV & TBSV

**Important!** There must be no obstructions to the Weatherseal opening fully as it will adversely affect the performance of the cooler.

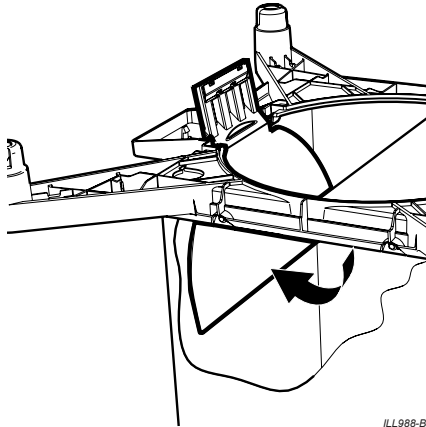

ILL988-B

### CONVEYING THE COOLER TO THE ROOF

**Caution!** Do not take risks when raising the cooler to the roof for installation. Use safety equipment, appropriate procedures and always have assistance.

It is recommended that at least 2 people move the cooler into position and that the transition, pad frames, venturi assembly and any unsecured objects are removed beforehand.

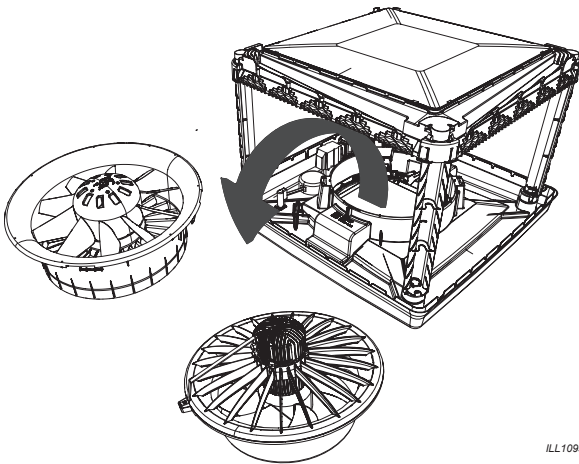

ILL1093-I

Carefully convey the cooler to the roof, avoiding scratching the unit and observing any WHS requirements. If you use a rope or sling, attach through the central tank hole. Do not use pillars. Do not drop the cooler. Always handle the cooler with care.

If you intend to pull the cooler onto the roof using a ladder as a slide, then guide the cooler on the underside of the tank.

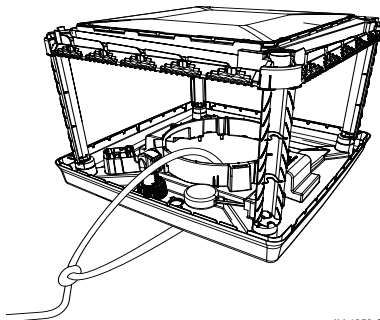

ILL1050-C

### CPQ, LCQ, TBQ, TBS, BMQ, TBQI, TBSI, LCQV, TBQV & TBSV Models

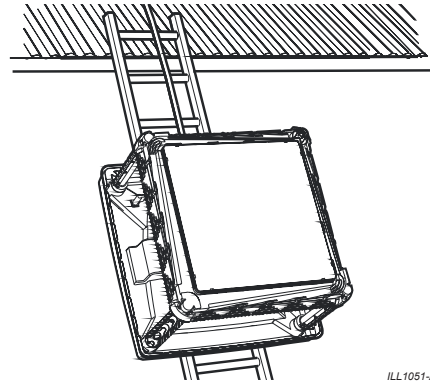

ILL1051-A

### EXTRA NOTES FOR LPQI & LPQV MODELS ONLY

Pull up the cooler on the tank, not the lid - to avoid damaging the rubber seals in the lid.

### MOUNTING THE COOLER

Once the cooler is on the roof, carefully lift the assembly onto the transition and into place. The assembly will only fit onto the transition in one orientation. Refer to the engraved details moulded into the transition.

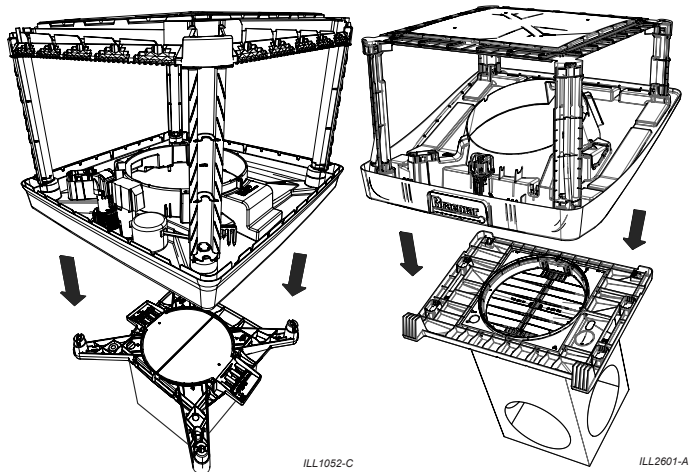

ILL1052-C

ILL2601-A

Ensure that the clips in all four corners engage correctly. Do not use any screws to fix the cooler to the transition.

**Important!** Do not place the venturi assembly into the cooler at this stage.

## INSTALLATION INSTRUCTIONS cont.

### CABLE INSTALLATION

#### For Australia

Your installation kit includes the power and control cables. Drop the power cable plug end along with the taped end of the control cable into the dropper duct. Route the power cable socket end with the control cable upwards through the corner hole in the transition and out the tank cavity as shown.

#### CPQ, LCQ, BMQ & LCQV, Models

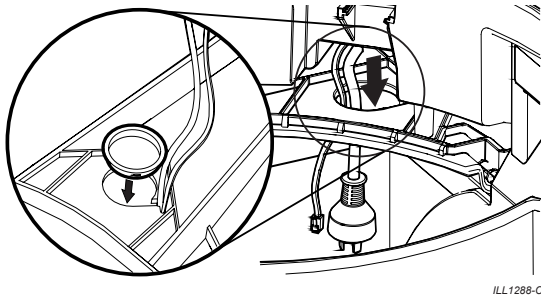

Lock the power cable socket in place by sliding the plug in sideways into the tank as shown.

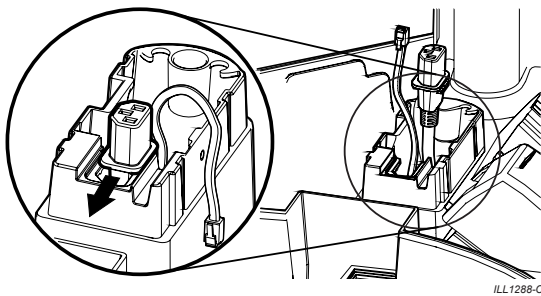

The plug will only insert one way, with the chamfered end first. For now, leave the control cable end in the tank as it will be connected later.

**WARNING!** Do not let cables, cable ends, or the control box get wet. Position the cables in the dropper so they will be accessible from inside the roof space.

Pass the cables through the grommet in the dropper. Place excess length of the cables in the roof cavity and not inside the cooler or dropper. Do not coil the power cable.

Push the cables into the cable slot in the transition as shown (control cable first) and then seal the hole with the plug provided.

#### LPQI & LPQV Models

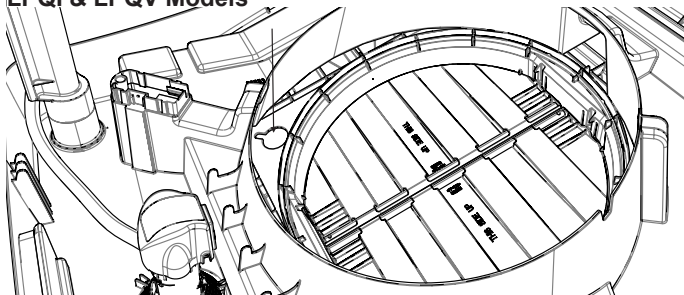

**Important!** Test the Weatherseal operation and ensure that the cables in the dropper do not interfere with the operation of the assembly.

#### For Rest of the World

Pass the taped end of the wall control cable through the conduit adaptor (factory fitted in the transition) and leave about 0.5m (20") in the water tank.

Take the power cable and drop the non-plug end down the hole where the electronics module was and pass it through the conduit adaptor. **Important!** Pass the wall control cable through the conduit first.

Lock the power cable socket in place by sliding the plug in sideways into the tank as shown. Now pass the cables through your main conduit and connect the main conduit to the conduit adaptor (under the transition).

Terminate the power cable in a junction box installed nearby. The fixed wiring must be fitted with an isolation switch that breaks the active (hot) and neutral (common) in accordance with local wiring rules. We recommend the junction box be located and installed on the duct.

Do not penetrate the duct near the Weatherseal.

**Note!** The maximum length for the wall control cable to travel alongside the power cable is 10m (33').

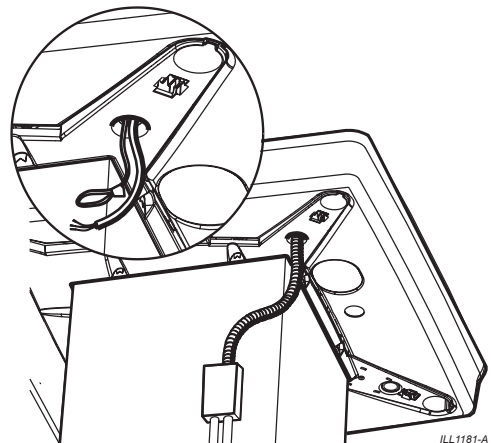



## INSTALLATION INSTRUCTIONS cont.

### INSTALLING THE VENTURI / FAN ASSEMBLY - CPQ, LCQ, TBQ, TBS, BMQ, TBQI, TBSI, LCQV, TBQV & TBSV

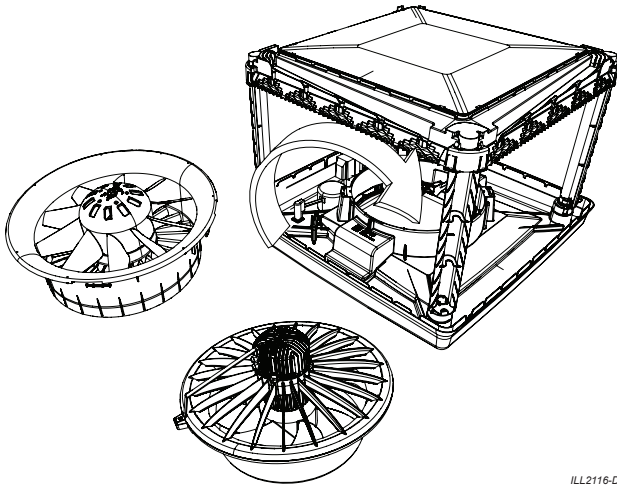

**Important!** Make sure the venturi is correctly and symmetrically located all the way around its cavity. Check this by making sure the venturi sits inside the locating ridge all the way around (C). Ensure the plug/lead assembly is not caught under the bottom lip of the venturi, by pulling the lead through fully.

Ensure the bottom of the lead is aligned with the bracket inside the tank. Failure to do this may result in the cable being caught between the outside of the bracket and the venturi (A). If fitted, route the motor tether through bracket at (A) and wedge it between the venturi and the tank at edge (B).

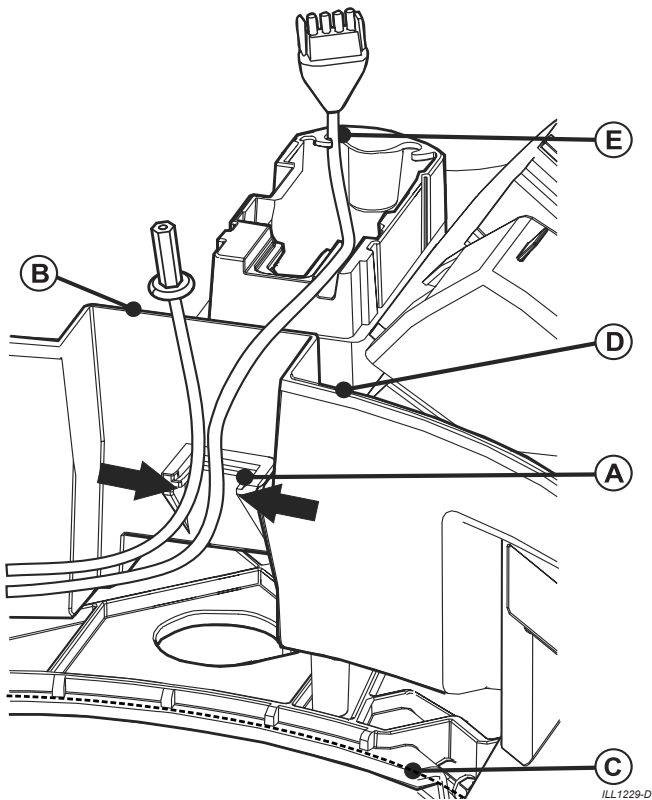

For TBQI, TBSI, LCQV, TBQV and TBSV coolers, ensure the venturi is sitting flat in the tank by checking all the venturi ribs are in contact with (D). It is recommended to relocate the tabs on the venturi back into the slots in the tank, as it was fitted during transport. The venturi securing screws (x2) do not need to be re-fitted.

### INSTALLING THE VENTURI / FAN ASSEMBLY - LPQI & LPQV

**Important!** Ensure the plug/lead assembly is not caught under the bottom lip of the venturi during installation by holding it out of the way.

Carefully lift the venturi / fan assembly into position inside the tank. Rotate the venturi until the ribs (2) on the venturi are touching the ribs (2) in the tank.

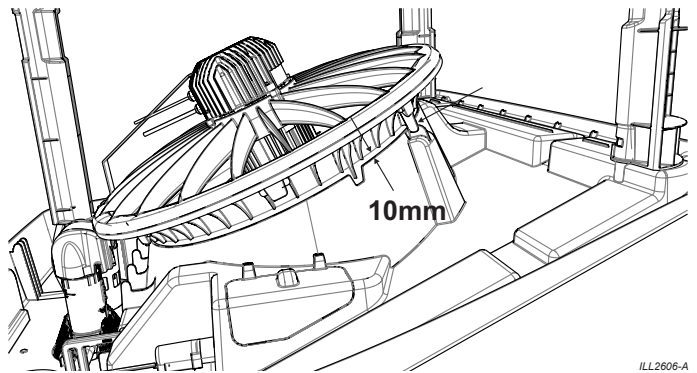

Ensure the venturi is sitting flat against the transition by checking all the venturi ribs are evenly spaced (10mm) from the top lip of the tank.

When in the correct orientation, the motor tether should slope down and towards the electronics box mounting point. The venturi securing screw(s) do not need to be re-fitted.

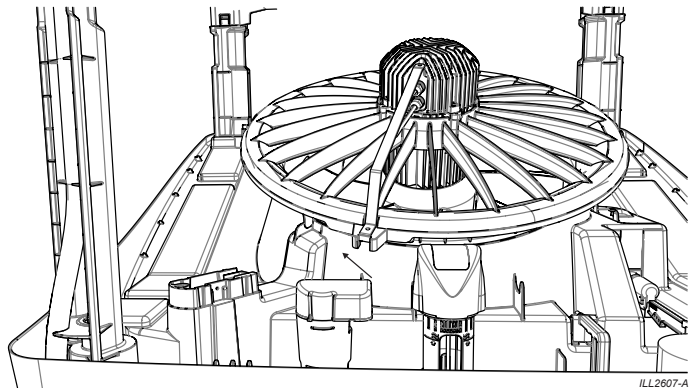

## WATER REQUIREMENTS

Installation of the cooler water supply must conform to local plumbing rules, regulations and standards.

**The following specifications for the cooler water supply are required:**

<b>Water Connection</b>	1/2" BSP
<b>Min Water Pressure</b>	100kPa (15psi)
<b>Max Water Pressure</b>	800kPa (115psi)
<b>Min Water Flow</b>	8 litres/min (2.1 gallons/min)
<b>Max Water Temperature</b>	40°C (104°F)

**Important!** If the water pressure exceeds maximum specification then a pressure reducing valve is required and must be supplied and fitted by the installer.

A permanent water supply is required to be connected to the cooler. The water connection point is located on the underside of the cooler.

You must install a manual 1/4 turn ball type shut off valve (do not use a stop cock) in the water supply line adjacent to the cooler, subject to local plumbing regulations. This allows the water supply to be isolated whenever work needs to be done on the cooler.

The water connection is a 1/2" BSP compression fitting or a 1/2" BSP to 1/4" compression fitting. This can fit directly onto the water pipe or be screwed directly onto the manual water shut-off valve.

Always ensure that the water pipe connection does not place sideways strain onto the float valve.

**Important!** In areas subject to freezing, the water supply line to the cooler requires a drain down facility at the lowest point in the water supply pipe.

**Important!** Flush the water pipe to remove any swarf before final fitting. Swarf can lodge in the solenoid and float valve, preventing them from functioning correctly.

## INSTALLING THE FLOAT VALVE - LPQI & LPQV

Assemble the float valve to the cooler as shown.

Ensure all washers and o-rings are in place. No thread tape is required. Do not over-tighten the plastic fittings.

Make sure the float is centrally positioned and up and down movement is unrestricted.

### LPQI & LPQV Models

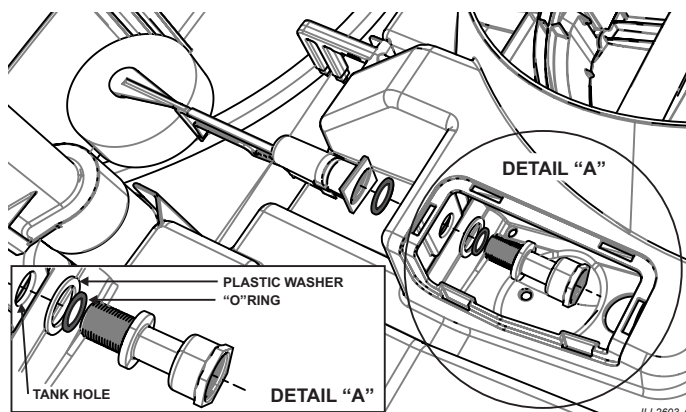

The plastic washer limits the outward expansion of the "O"ring during tightening compression.

### LPQI & LPQV Models

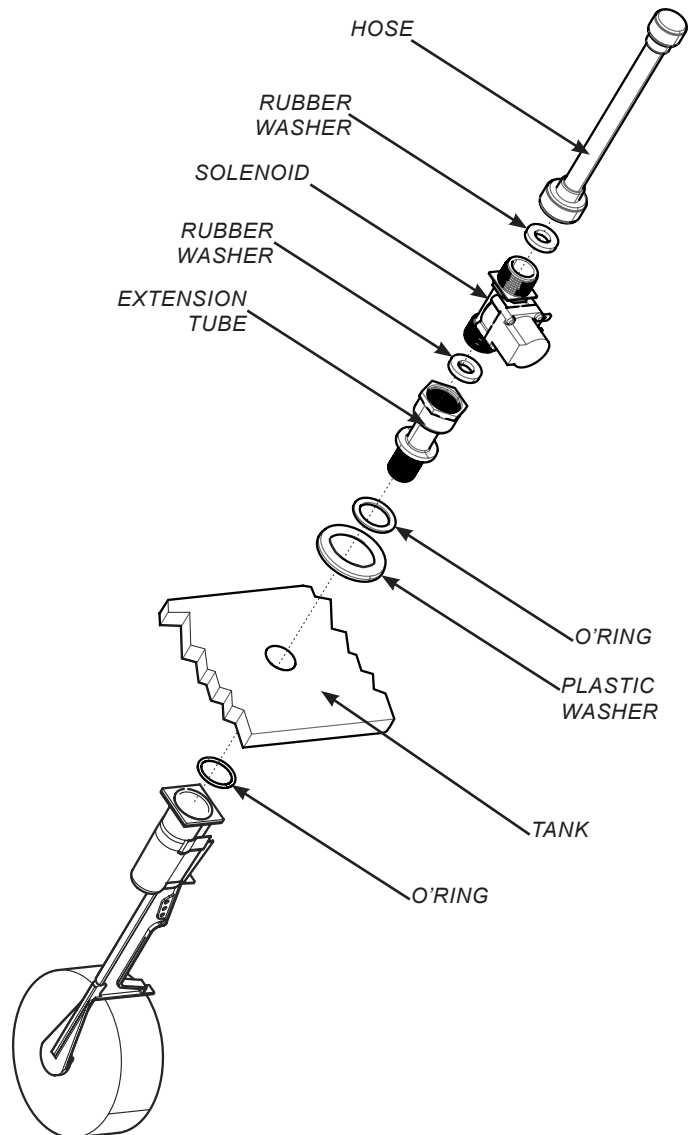

ILL2770-A

## WATER REQUIREMENTS cont.

### INSTALLING THE FLOAT VALVE - CPQ, LCQ, TBQ, TBS, BMQ, TBQI, TBSI, LCQV, TBQV & TBSV

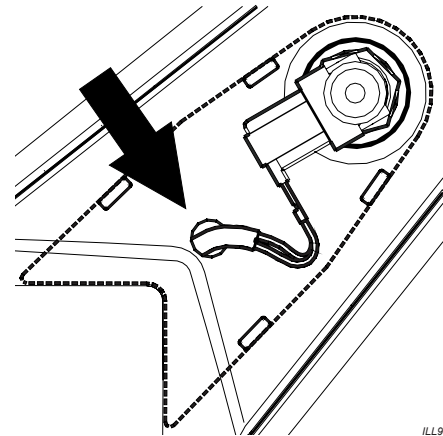
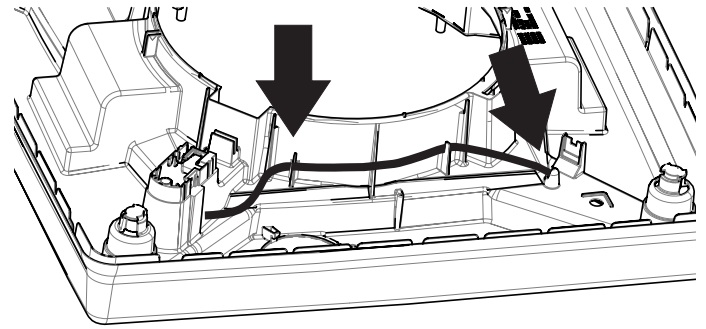
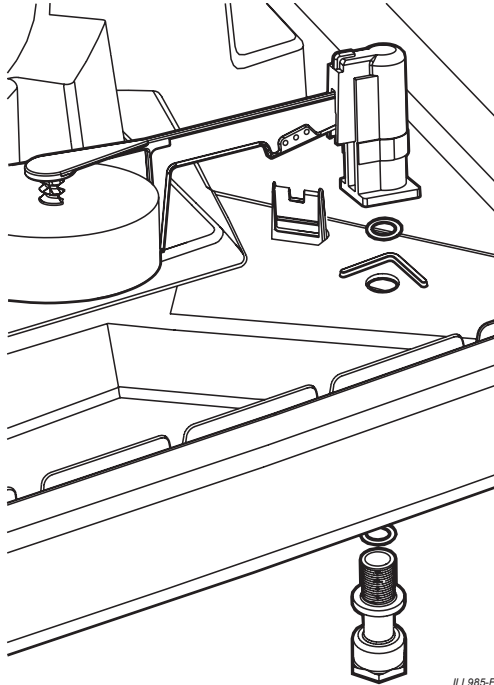

Clip the solenoid cover in place and connect the flexible hose to the mains water supply.

### INSTALLING THE INLET SOLENOID - CPQ, LCQ, TBQ, TBS, BMQ, TBQI, TBSI, LCQV, TBQV & TBSV

For coolers fitted with a drain and solenoid valve, it is a requirement to fit the new detachable hose set supplied. Any old hose sets should not be re-used.

Screw the solenoid valve into the extension tube.

**Note!** Tighten the solenoid valve until it seals against the rubber washer and is in the orientation shown such that the solenoid cover will clip on over the top.

The water solenoid is required to be installed in the direction of flow as per the arrow indicator on the solenoid.

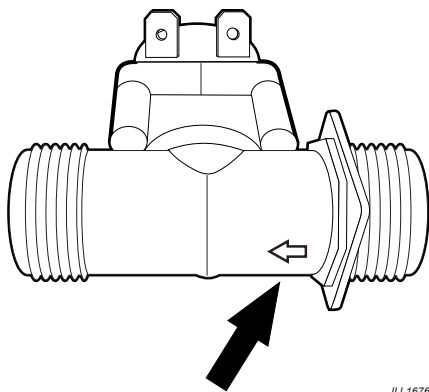

Connect the supplied cable to the solenoid valve, then push the other end through the hole in the transition as shown. Pull the cable through from inside the cooler and route the cable as shown. This will be connected later.



## WATER REQUIREMENTS cont.

### INSTALLING THE INLET SOLENOID - LPQI & LPQV

Connect the supplied cable to the solenoid valve, then push the other end through the hole in the solenoid cover before fitting the solenoid cover to the tank.

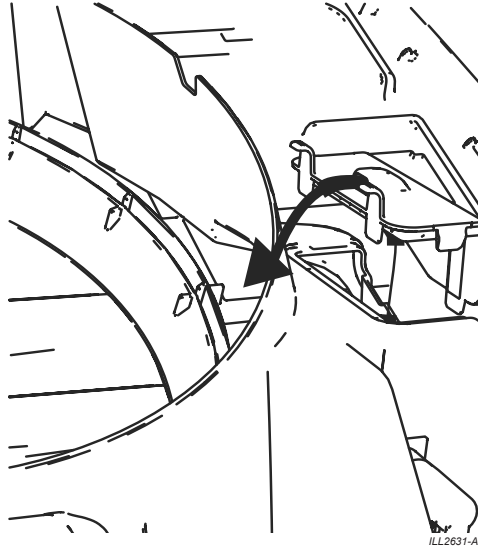

Pull the cable through from inside the cooler and route the cable as shown. This will be connected later.

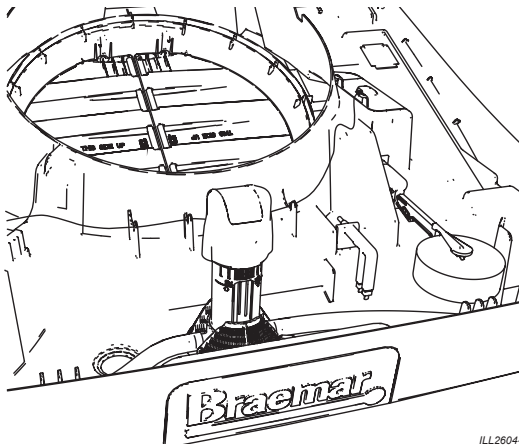

### INSTALLING THE WATER SENSOR

Assemble the water sensor as shown by clipping the sensor to the tank. Ensure that the clip fully engages.

Route the sensor cable through the cable supports in the tank as shown and leave the end clear of any water. The cable will be plugged in later.

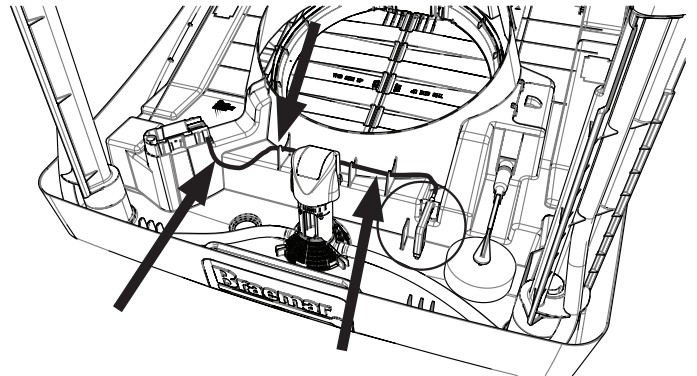
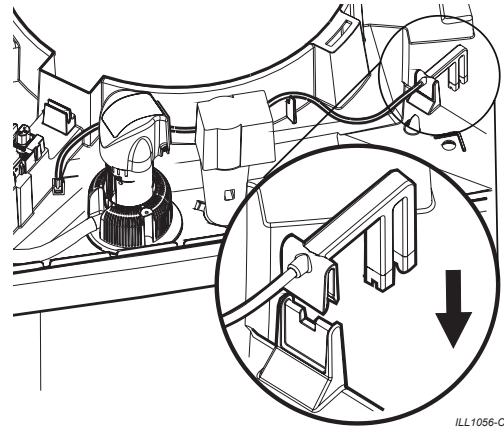

## WATER REQUIREMENTS cont.

### MAINS WATER CONNECTION

For bleed funnel option, a 3/4" to 1/2" BSP adaptor is to be fitted with the washer to the extension tube as shown!

Connect the main water supply to the water inlet point under the air cooler using the 1/2" BSP Nut and olive fitting or 1/2" BSP - 1/4" brass compression adaptor fitting as required.

Always install a shut-off valve (do not use a non-return type valve) close by the air cooler.

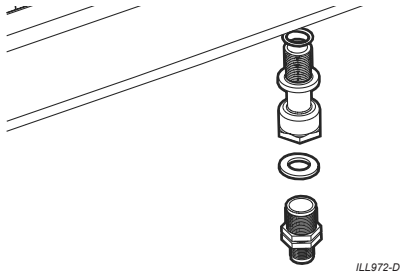

### INSTALLING THE DRAIN VALVE

Water drained from the cooler must be carried away to a suitable discharge point in accordance with local regulations. Important! Never drain water from the cooler directly on to the roof. Assemble the drain valve (1) as shown:

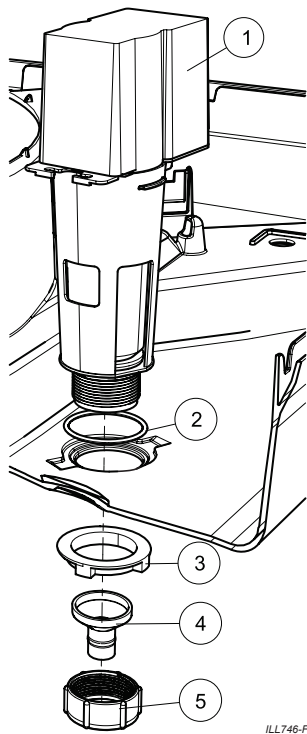

Ensure the "O"-ring (2) is fitted to the drain valve spigot and this is seated inside the tank. Screw the smaller nut (3) up tightly by hand to fix in place. Locate the funnel (4) against the bottom of the drain valve spigot thread and secure with the larger nut (5). Ensure that you use the correct drain adaptor. **Important!** Do not over-tighten plastic fittings.

### TUNDISH INSTALLATION

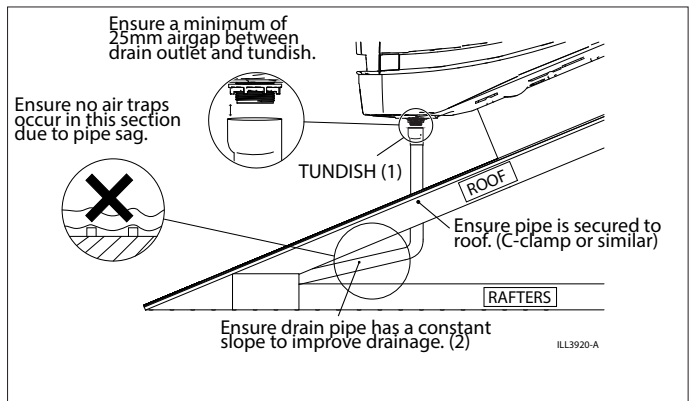

Installations with outlet hoses larger than Ø 20mm I.D. should have an installer supplied tundish (1) fitted under the drain outlet with a 25mm air-gap to improve serviceability and warranty.

Ensure the drain pipe has a constant slope (without undulations) towards the ground, so water discharges freely away from the cooler (2).

## WATER REQUIREMENTS cont.

### BLEED FUNNEL

(Model Dependent – refer to your dealer)

The bleed funnel reduces the accumulation of salts and minerals in the cooler. It also acts as an overflow and a drain.

Assemble the bleed funnel as shown.

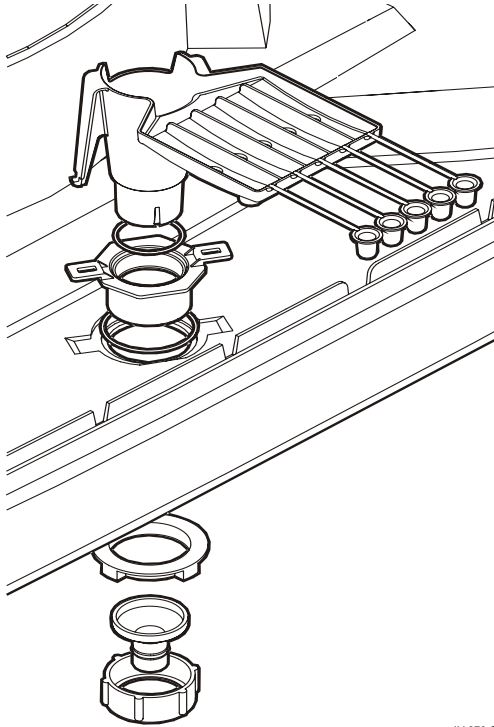

ILL970-C

Make sure the bleed funnel is correctly oriented and that the o-rings are fitted before placing it into the hole. Screw the nut up tightly by hand underneath the cooler.

Make sure that you use the correct drain adaptor. Drain-water from the bleed funnel must be carried away to a suitable discharge point on the building or property in accordance with local regulations. Do not drain directly onto the roof surface.

The bleed rate required will vary according to water quality, but should initially be set to the minimum rate as outlined in the table below (COOLER MODELS BLEED PLUG SET).

Push the remaining plugs into the blind holes provided. In poor quality water areas where the salt and mineral contents are high, adjust the bleed rate by inserting one or more extra plugs than specified in the table.

**Note!** If the water sensor is fitted, you will need to disconnect it from the Electronics Module and remove it from the cooler completely. Then fit the shorting plug (supplied in the Bleed kit) to the socket where the water sensor was fitted (Page 20 - Electrical Connection).

COOLER MODELS BLEED PLUG SET	
1 Plug in bleed set hole	2 Plugs in bleed set hole
LCQ250, LCQ350, LCS280, LCS380, BMQ650, CPQ450, CPQ700, TBQI350, TBQV350.	LCQ450, LCQ550, LCS480, LCS580, BMQ850, BMQ1150, CPQ850, CPQ1100, TBQ500, TBS500, TBQ550, TBS580, TBQI550, TBSI580, TBQV550, TBSV580.

# ELECTRICAL REQUIREMENTS

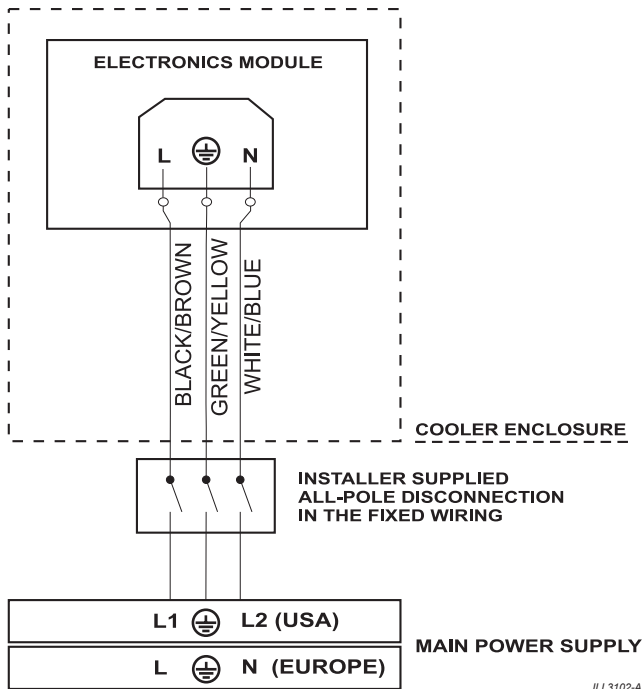

ILL3102-A

Installation of the cooler must conform to local electrical rules, regulations and standards.

**Important!** It is a requirement of Seeley International that all coolers be connected to a dedicated circuit to the distribution board, with a separate circuit breaker and incorporate means to ensure all-pole disconnection from the supply mains, in accordance with local and national wiring rules.

In Australia, a 10A socket outlet within one metre of the dropper's cable exit hole is required.

The following specifications for the cooler electrical supply are required: **220 - 240V / 50 or 60Hz Single Phase.** (See nameplate for exact data in cooler)

**For BMQ, CPQ, LCQ, LCS, TBQ & TBS models:**

The electronics module is fitted with a 12A re-settable circuit breaker. To reset the circuit breaker turn off the isolation switch, remove the electronics module and push the manual reset toggle switch located underneath the electronics module.

**EXTRA NOTES FOR LPQI / TBQI / TBSI / LCQV / LPQV / TBQV / TBSV MODELS ONLY**

The electronics module is fitted with an anti-surge fuse in place of the 12A circuit breaker.

**WARNING!** If the supply cord is damaged, it must be replaced by the manufacturer, its service agent or similarly qualified persons in order to avoid a hazard.

## ELECTRICAL CONNECTION

Connect the motor cable to the base of the electronics module. It is a polarised plug and will only insert one way. Ensure it is secured fully so that its retention clips are engaged.

Route the end of the wall control cable out of the cavity via the same channel as the motor cable. Ensure you have about 200mm (8") of wall control cable outside the cavity.

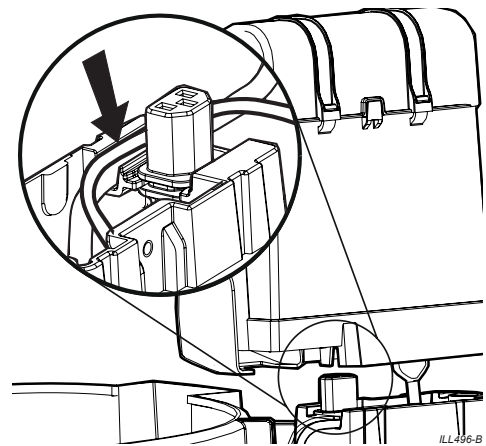

ILL456-B

With both cables in place (inside the channel), re-assemble the electronics module and screw it to the tank.

**Important!** The isolation switch cannot be activated unless this screw is fixed in place.

Switch OFF the electronics module before connecting any accessories.

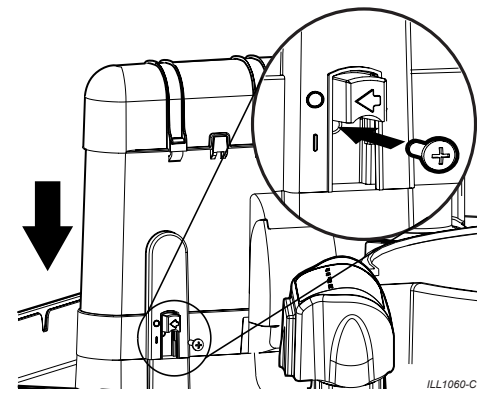

ILL1060-C

**For BMQ, CPQ, LCQ, TBQ and TBS coolers**

Connect the water sensor plug (D) and inlet solenoid plug (C) as shown.

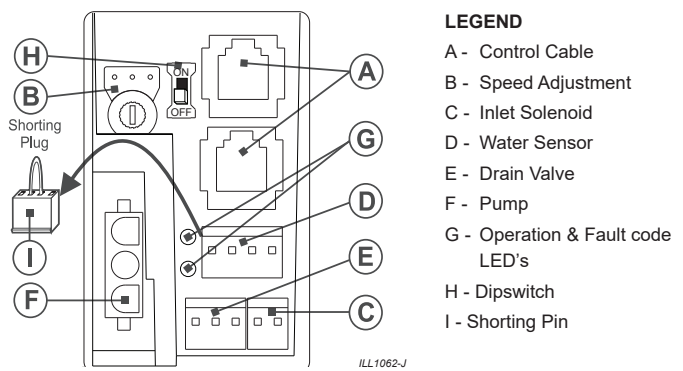

ILL1062-J

**Note!** Fit either the shorting plug or water sensor as required.

# ELECTRICAL REQUIREMENTS cont.

## ELECTRICAL CONNECTION - cont

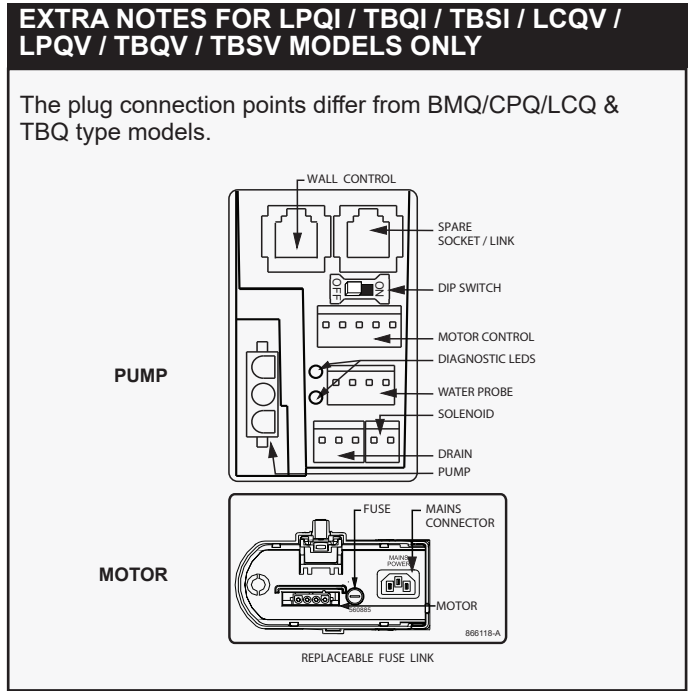

### LPQI & LPQV Models

Route the drain valve cable as shown before connecting it to the electronics module.

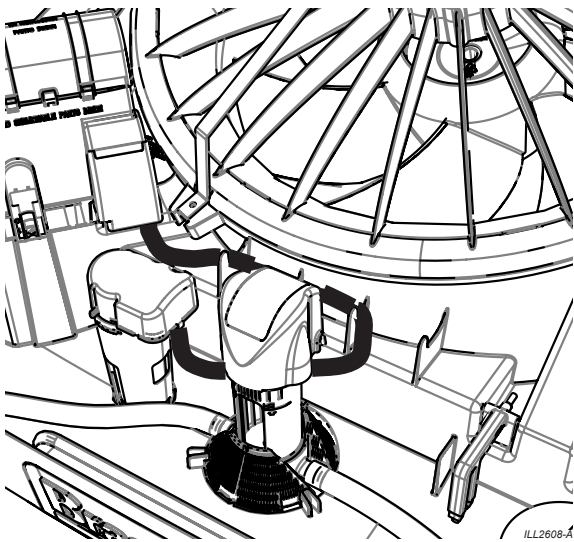

Ensure the cables cannot rest in the water once the tank is filled and plugs are connected in the correct orientation.

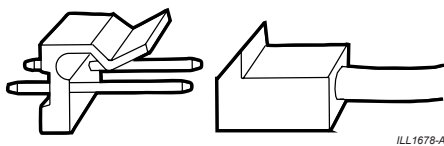

### For BMQ, CPQ, LCQ, TBQ, TBS, TBQI, TBSI, LCQV, LPQV, TBQV & TBSV models

Route the drain valve cable as shown before connecting it to the electronics module (E).

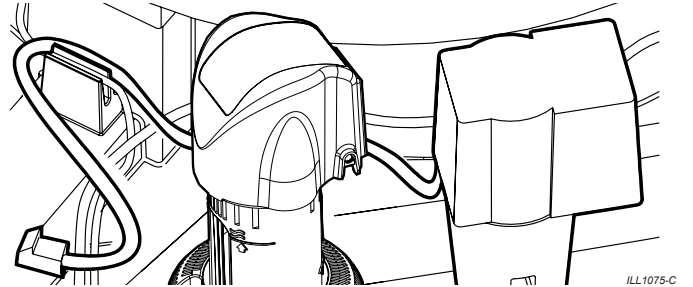

Ensure the cables cannot rest in the water once the tank is filled and plugs are connected in the correct orientation.

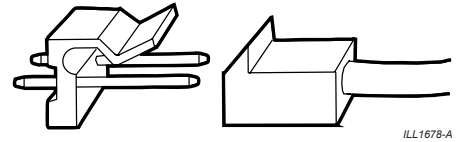

### MULTIPLE COOLER INSTALLATIONS

Multiple coolers can be linked together using a common MagIQtouch wall control.

Ensure all cooler electronics dipswitches are set to 'OFF' except for the last cooler in series. The last cooler dipswitch should be switched to 'ON' to ensure communication reliability.

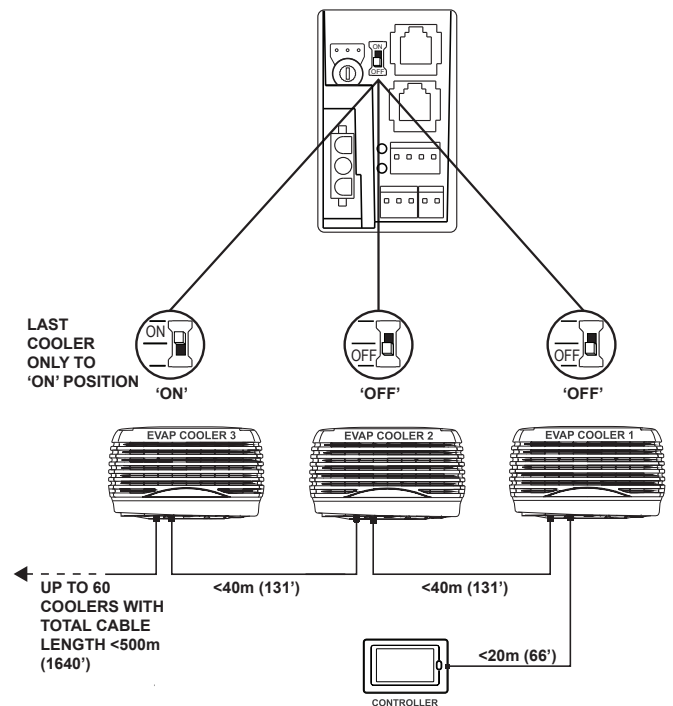

ILL2330-E

## CONNECTING THE WATER PUMP

Route the pump cord as shown.

### BMQ, CPQ, LCQ, TBQ, TBS, TBQI, TBSI, LCQV, TBQV & TBSV models

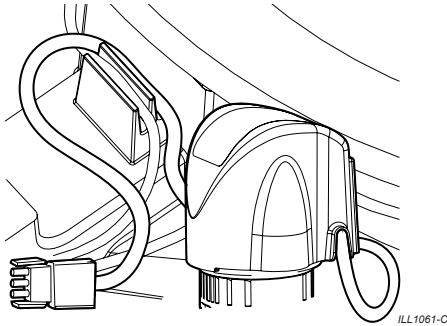

### LPQI & LPQV Models

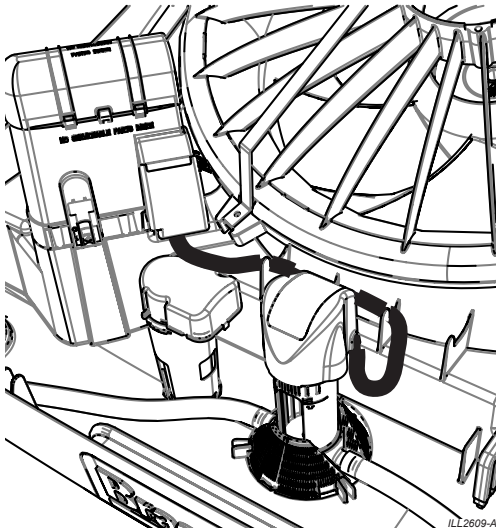

Once the water level is set correctly, isolate the electronics module and connect the pump plug.

**Important!** Do not connect the pump plug until the water level is set.

**WARNING!** Do not run the pump while the pad frames are off and the fan is on.

Once plugs are connected, switch the electronics module on.

**Important!** Ensure the flexible splash protection cover is in place.

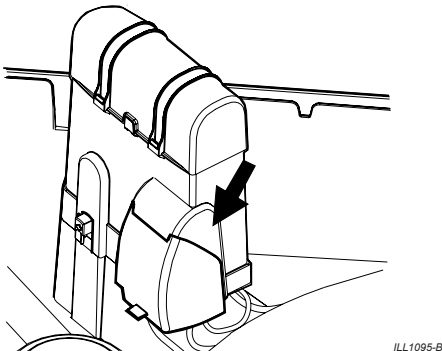

### For BMQ, CPQ, LCQ, TBQ and TBS models

Connect the pump plug (F) as shown.

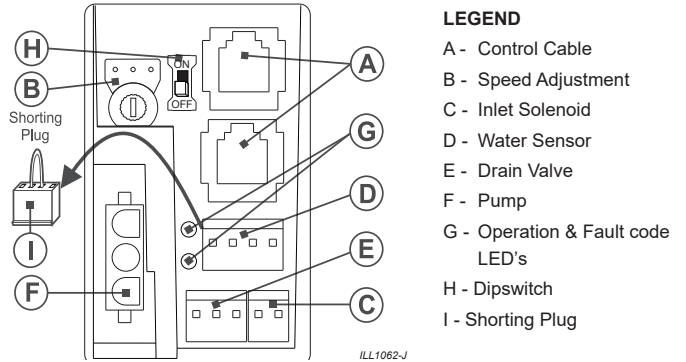

#### LEGEND

- A - Control Cable
- B - Speed Adjustment
- C - Inlet Solenoid
- D - Water Sensor
- E - Drain Valve
- F - Pump
- G - Operation & Fault code LED's
- H - Dipswitch
- I - Shorting Plug

**Note!** Fit either the shorting plug or water sensor as required.

### EXTRA NOTES FOR LPQI / TBQI / TBSI / LCQV / LPQV / TBQV / TBSV MODELS ONLY

The plug connection points differ from BMQ/CPQ/LCQ/TBQ and TBS type models.

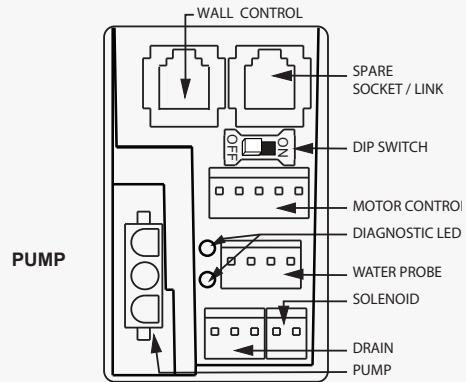

## CONNECTING THE MAGIQTOUCH / MAGIQCOOL CONTROLLER

Refer to the installation manual provided with the MagIQtouch Controller for instructions on installing the controller. The wall control cable plugs into the electronics module - (A) (refer diagram adjacent). Coolers are supplied with a 20m (66') control cable. Longer cable lengths are available from Seeley.

**Important!** The maximum cable length allowed from the MagIQtouch Controller to the first cooler is 20 metres (66'). For any additional coolers added into the system with a link module the maximum allowed length is 40 metres (131'). Therefore, failure of the product or components to operate correctly due to modification to supplied cables, or the use of non-approved cables will NOT be accepted under the Manufacturer's Warranty.

We have this cable available through our Sales order office and spare parts outlets in the following lengths:

Part No.	Length	Details
833880	20m	MagIQtouch Controller Cable (No Ferrite)
823553	20m	MagIQtouch Controller Cable EXQ/EXS (With Ferrite)
862873	1.5m	MagIQtouch Controller Cable (No Ferrite)
861265	3m	MagIQtouch Controller Cable (No Ferrite)
864396	30m	MagIQtouch Controller Cable EXQ/EXS (With Ferrite)
864402	40m	MagIQtouch Controller Cable EXQ/EXS (With Ferrite)



## MAGIQCOOL CONTROLLER DISPLAY INFORMATION

### MAGIQCOOL WALL CONTROL DISPLAYS “SERVICE”

If on initial Installation of a Cooler, or after the wall control has been changed, the word “SERVICE” appears on the MagIQcool Wall control screen and the unit does not respond to the pushing of any buttons even though the backlighting responds.

This is easily rectified and means that communication needs to be established between the Wall control and the electronic controller inside the Cooler.

To establish communications simply push and hold the “DOWN” button until the word “SERVICE” disappears from the screen and the temperature appears. This may take up to 10 seconds. Once communications has been established the unit can be operated. If by pushing the on/off button a number appears, see “FAULT CODES INDICATED BY LED’S ON THE COOLER ELECTRONICS MODULE” on page 28.

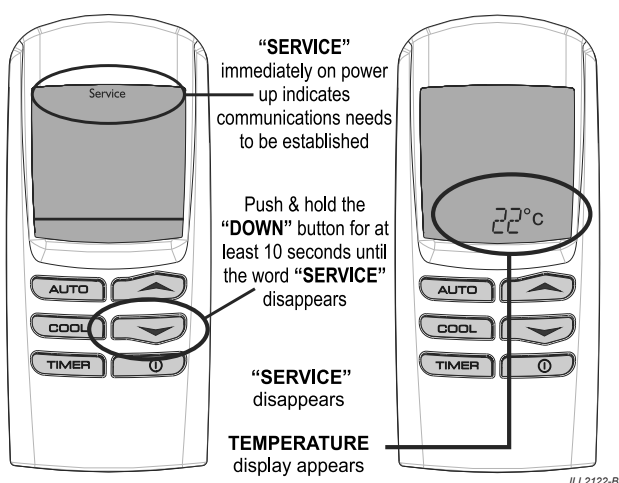

## MAGIQTOUCH CONTROLLER DISPLAY INFORMATION

Diagnosis and cooler operating information can also be viewed from the MagIQtouch Controller. Faults are displayed on the screen as they occur.

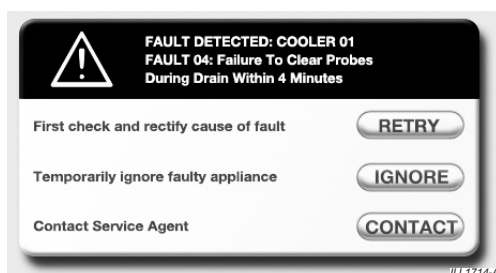

Cooler operating information is available from the ‘Service Operating Screen’ under the COOLER tab of the SETTINGS menu.

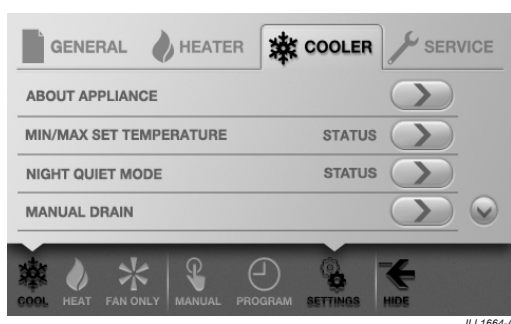

## CHANGING THE WATER MANAGEMENT METHOD FOR THE MAGIQCOOL CONTROL

To enter Parameter mode, the following process must be carried out within 4 minutes of power being applied to the cooler. If unsure of time since the last power “ON”, remove power to the cooler (Isolator Switch or Circuit Breaker) for a minimum of 6 seconds so the mode can be entered.

1. While wall control is OFF, push and hold “AUTO” and “DOWN” button for minimum three (3) seconds.
2. When parameter mode has been entered, screen will display “A1” - (Water Salinity Control Method) and “Param”.
3. To view parameter number set in wall control press “AUTO” momentarily. Figure “A#” on screen will change to number set, and “Param” will change to “value”.
4. To alter the “value” of selected parameter press “UP” or “DOWN”. Numbers will change to show different values the parameter can be set to.  
**Water Manager = 0**  
**Timed Drain (CPQ/BMQ Upgrade Kits) = 1**  
**Non-Drain Valve salinity control (bleed etc) = 2**
5. To store the value, press “AUTO”. Screen will go blank momentarily as wall control stores parameter change, and returns screen to “A#” and “Param”.
6. To exit parameter mode or escape from an alteration without storing a change press “0” button instead of “AUTO” button. Remember, once step 5 has been carried out, new parameter change is permanent until again altered.
7. If no buttons are pushed on wall control, after 3 minutes screen will reset to “OFF” state. Procedure to enter parameter mode must be re-initiated.

For models where water management probes and drain valve are fitted, the drain frequency is typically managed by salinity control. There should be no need for adjustment. However if you do wish to change from salinity control to a set interval timed drain, follow these programming steps.

While the thermostat is OFF, hold down “AUTO” for at least 3 seconds and then press “DOWN” while still pressing “AUTO”.

The setting “A1” will be displayed, release both buttons and then press “AUTO”.

A number will now be displayed. Press “UP” or “DOWN” until the number displayed corresponds to the desired setting;  
0 = Salinity Control  
1 = Timed Drain.

Press “AUTO” to complete the adjustment. Exit the programming mode by pressing “0”.



## SETTING THE WATER LEVEL

Isolate power to the cooler electronics and disconnect the pump, making sure the plug is kept away from any water. Turn the power back on.



ILL1663-A

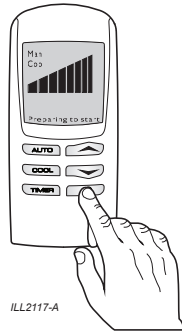

ILL2117-A

Turn on the mains water supply to the cooler.

Turn the cooler on at the controller, in "COOL" mode.

Adjust set temperature slider / fan speed buttons to be close to current room temperature so that fan speed remains low.

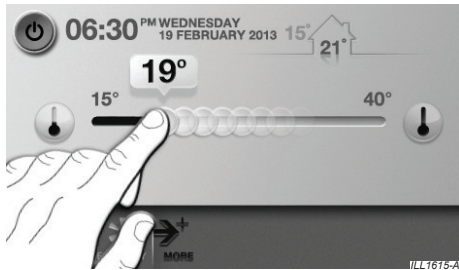

ILL1615-A



ILL2118-A

Allow the tank (reservoir) to fill with water. The float valve will eventually stop the water from entering the cooler. Wait for this to happen and check the water level.

**BMQ, CPQ, LCQ, TBQ, TBS, TBQI, TBSI, LCQV, LPQV, TBQV & TBSV Models**

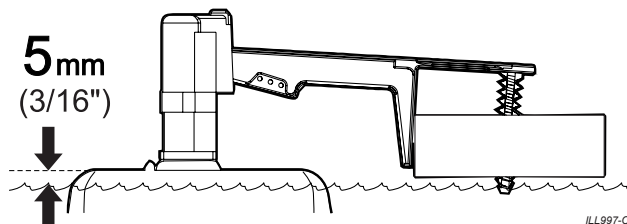

ILL997-C

If the level is too high rotate the float clockwise. Drain some water from the tank and allow it to refill to the new set point.

If too low rotate the float in an anti-clockwise direction. The correct water level is approximately 5mm below the surface of the tank the float valve is mounted on. It is advisable to check the water level again after the float valve washer has "bedded in".

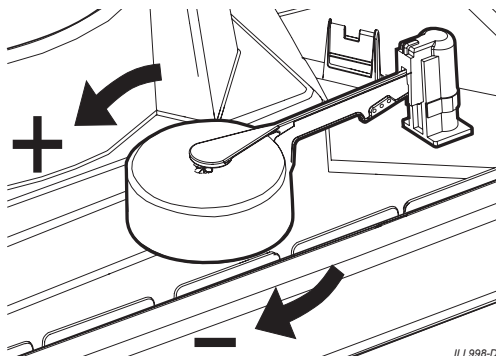

ILL998-D

### EXTRA NOTES FOR LPQI & LPQV MODELS ONLY

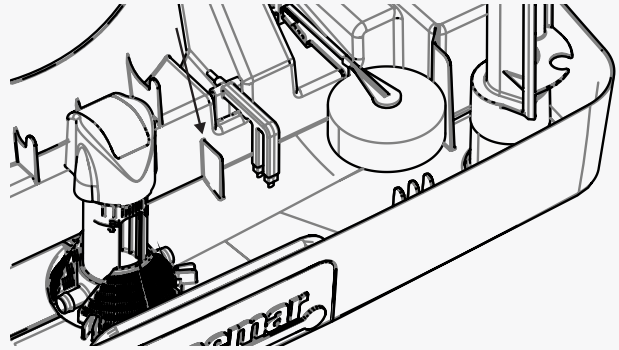

Locate the **rib** inside the tank next to the water sensor. The **top** of this rib indicates where the water level should reach when the tank is full.

Once the water level is correct, isolate the control box and connect the pump plug.

## COMMISSIONING THE COOLER

### TEST OPERATION

Check that the green light on the electronics module is on and double flashing every 2 seconds. This indicates that power is connected to the electronics module.

**Important!** Ensure the flexible splash protection cover is put back in place.

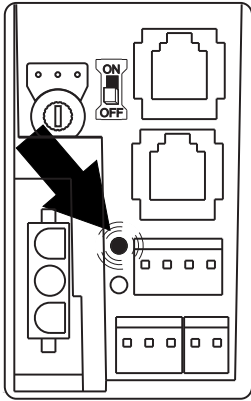

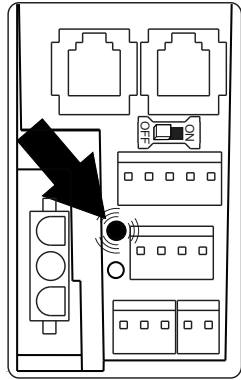

ILL1014-J

BMQ, CPQ, LCQ, TBQ, TBS  
Coolers



ILL2120-C

LPQI, TBQI, TBSI, LCQV,  
LPQV, TBQV, TBSV Coolers

**Note!** If on initial start up the word “Service” appears on the controller and by pushing the  button nothing changes on the display, then you will need to establish communication between the wall control and the electronic controller. Simply push and hold the  button for approx. 10 seconds or until the word “Service” disappears. If by pushing the  button a number appears refer to the fault codes.

### BMQ, CPQ, LCQ, TBQ, TBS, TBQI, TBSI, LCQV, TBQV & TBSV MODELS

#### REFITTING THE PAD FRAMES

Refit the pad frames by locating the bottom edge in the tank groove, then push the top into the lid.

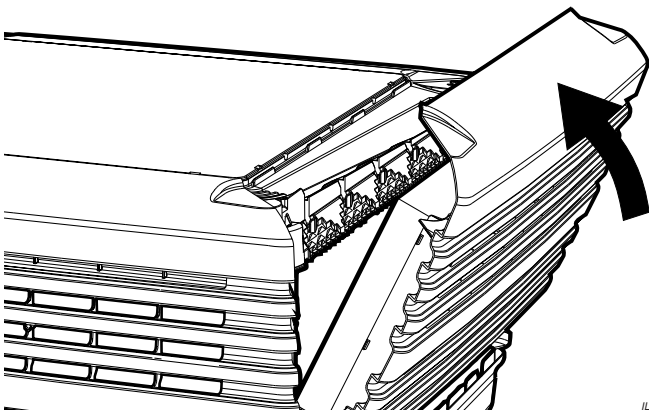

ILL976-D

### SUPERCOOL PAD POSITIONS

All Supercool Chillcel pads for LCS/TBS/LCSV/TBSI/TBSV coolers have the side edges rebated to provide clearance for corner posts. Note the position required for the pad with the Drain Valve (“B” Rebate) rebate.

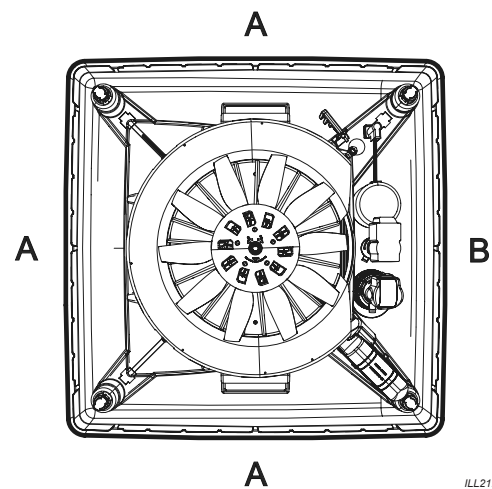
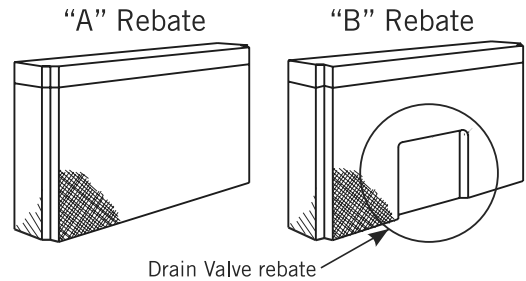

ILL2128-A

**If fitted incorrectly they may cause problems:**

- Thicker pads may catch on internal components causing damage.
- Thicker pads may impede the correct operation of the float valve.
- Incorrect positioning of pads may cause a drop in cooler performance.
- Incorrect fitment may allow water to bypass the pad and be carried over into the air stream and ducting.
- Water bypass may cause damage to internal electronic components.

## COMMISSIONING THE COOLER cont.

### BRAEMAR LPQI & LPQV MODELS

#### REMOVING THE PAD FRAMES

The pad frames are designed to overlap and interlock and so must be removed in a specific order.

At each corner of the cabinet where the padframes overlap there are 2 clips. These clips will need to be pushed in and disengaged before the pad frames will pull free.

Depress the 4 side clips to release the front pad frame first. **Important!** Be careful not to use excessive force when pushing in the clips to avoid damaging them. Remove the front pad frame. Then release the 2 side panels from rear in the same way. Finally remove the rear panel.

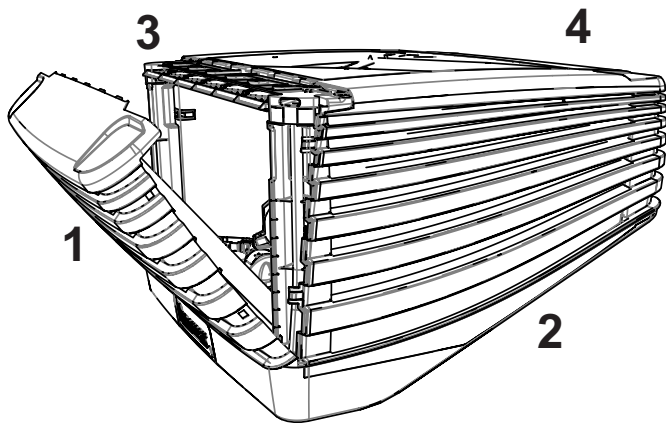

ILL2591-A

**Important!** Be careful not to use excessive force when pushing in the clips so as not to damage them.

#### REFITTING THE PAD FRAMES

Refit the pad frames by locating the bottom edge in the tank groove, then push the top into the lid. The order in which pad frames are removed and refitted is important to avoid breaking them. The pad frames are designed to overlap and interlock and so must be assembled in a specific order.

Assemble the rear pad frame first by locating the bottom edge inside the lip of the tank and rotating it forwards. Ensure the retainment lugs along the top of the padframe are fitted securely into the lid.

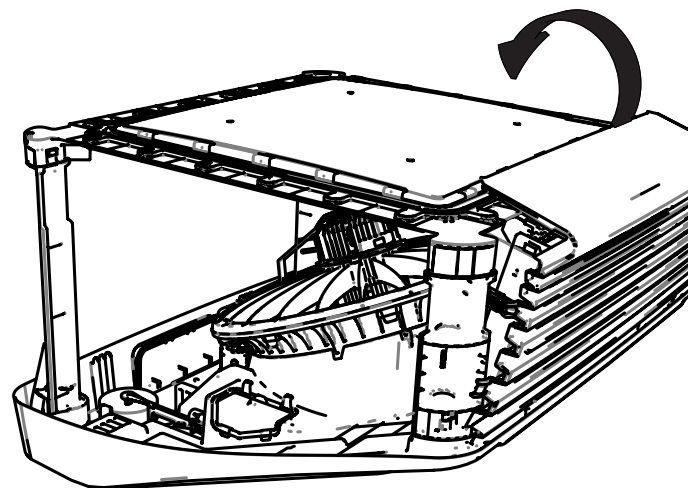

ILL2578-A

Once the rear pad frame is assembled, the 2 side pad frames can be fitted in the same way.

Ensure the clips between the rear and the side panels are fully engaged.

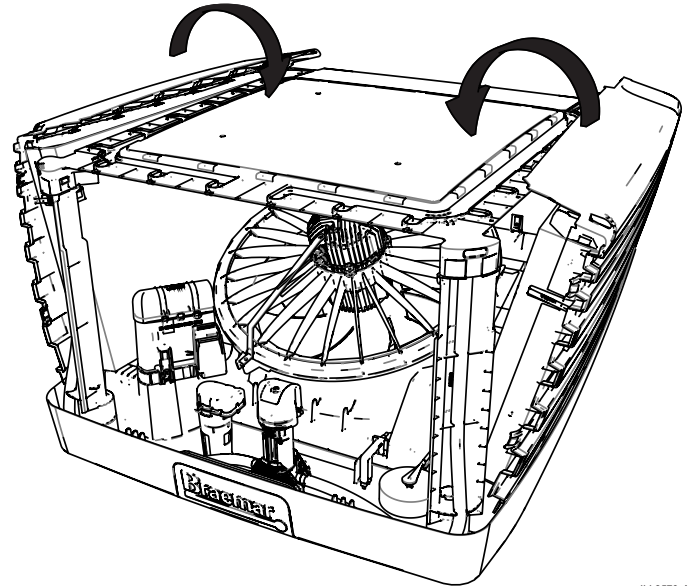

ILL2579-A

Assemble the front pad frame.

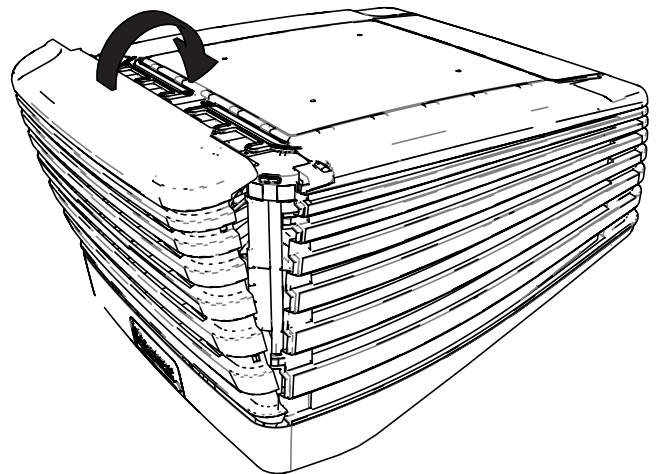

ILL2580-A

Where each of the padframes overlap there are 2 clips. Ensure all the clips are fully engaged.

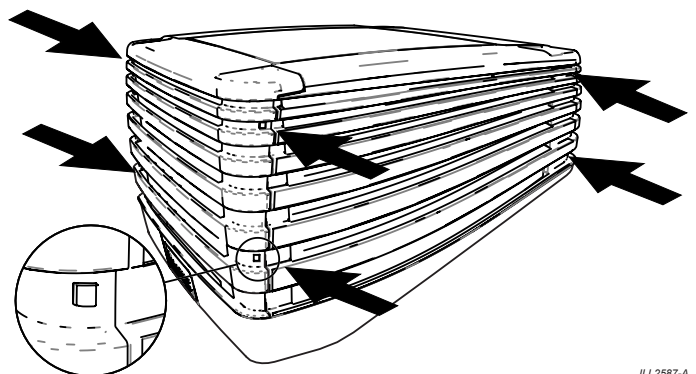

ILL2587-A



## COMMISSIONING THE COOLER cont.

### TESTING THE PUMP

Test the pump by turning the cooler on at the controller, in “COOL” mode. Check that water is evenly distributed to all pads.

**Note!** If the cooler has not been on before it will run a “Pre-Wet” routine where the pump will operate to saturate the pads. This cycle takes 2 minutes, then the fan will start automatically.

### TESTING THE DRAIN VALVE

With the wall control in “OFF” mode, press and hold the  and  buttons together for 1 second on the MagIQcool controller, “dr” is displayed and the drain valve will open.

Select the “SETTINGS” mode on the MagIQtouch Controller and select the “COOLER” sub-heading. Select the “MANUAL DRAIN” option to operate and test the drain valve.

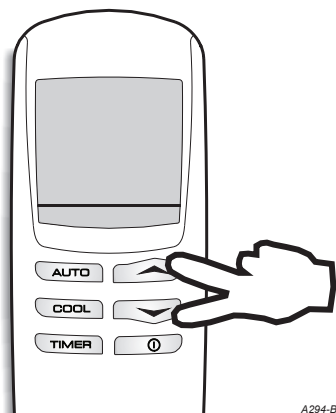

## COMMISSIONING COMPLETION CHECKLIST

### COOLER

- SECURE - The cooler is secure and level on the dropper using all fixings supplied.
- SEALED - The dropper and all penetrations are correctly flashed and sealed.

### WEATHERSEAL

- OPERATES - The Weatherseal operates correctly and can open and close without interference.

### PLUMBING

- FLUSHED - The water pipes were flushed of any foreign materials before connection to the cooler was made.
- NO EXTERNAL LEAKS - The water is connected with no leaks at fittings.
- NO INTERNAL LEAKS - Check the internal water hose is securely fitted to water distribution spreader on the lid and to the pump.
- SECURE - Water pipes are correctly saddled as per plumbing regulations.
- OWNER INSTRUCTIONS - The owner has been instructed on how to isolate the water to the system in case of emergency.

### DRAIN VALVE

- INSTALLED - The drain valve is installed correctly, as detailed in this installation manual.
- DISCHARGE - The drain water does not discharge onto the roof surface.
- WATER LEVEL - Water level has been set correctly, as detailed in this installation manual.
- TESTED - Drain the tank manually. Check the drain fittings and pipes, making sure there are no leaks.

### POWER

- REGULATIONS - The power supply adheres to all local and national regulations and is wired back to the distribution board on its own separate circuit.
- CHECK CABLES - Cables have been correctly connected to the control boxes:
  - Power supply
  - Motor cable(s)
  - Control cable
  - Drain valve
  - Solenoid cable
  - Pump cable
  - Probe cable
- OWNER INSTRUCTIONS - The owner has been instructed how they can electrically isolate the unit at the meter box in case of an emergency.

### DUCTWORK

- NO LEAKS - All ducts are hung correctly and there are no air leaks.
- CONTROLLER SEALED - All wall holes behind the controller have been sealed.
- QUIET - Check that the cooler runs quietly and with an even distribution of air to all outlets.
- AIRBALANCE – The air balance for all outlets has been adjusted to the customer’s satisfaction.

### FLUSHING CHILLCEL PADS

- PADS FLUSHED - To prevent initial start-up odours from the cooling pads, it is a requirement to flush water through them and drain the tank. Operate in COOL mode, lowest speed for 5 minutes, then drain the tank. Repeat several times if necessary.

### FINAL TEST

- Once you are satisfied that the cooler is installed and commissioned correctly, run the cooler and ensure that everything is working as it should.

### CUSTOMER HANDOVER

- Principles of Ducted Evaporative Cooling explained.
- How far the windows need to be opened.
- How to turn the cooler on.
- How to operate the controller.
- How to drain the cooler.
- How to turn the power and water off.
- Maintenance requirements.
- The customer has been given the Owner’s Manuals & Warranty Card.

### CLEAN-UP

- All the installation rubbish has been removed and, if applicable, any property damage repaired. Your aim should be to have the customer not even be aware that you have been on site.

### FINAL CHECK

- With all side panels in place and the unit running for a short period in cooling mode, ensure all pads have even water saturation and there are no visible water leaks



## ADJUSTING COOLER SETTINGS

Within the SETTINGS menu of the MagIQtouch Controller is the COOLER sub-heading. Here various settings of the cooler can be adjusted.



### About Appliance

Displays information such as model number, serial number and software version for all coolers connected to the controller.

### Night Quiet Mode

Restricts fan speed to a specified level during a specified night period.

### Manual Drain

Turns cooler off and drains the tank.

### Pad Flush

Turns cooler off and runs pump for a specified amount of time.

### Auto Restart

By turning this option to 'ON', the cooler will automatically restart after a power failure.

### Drain and Dry

Cooler will drain and fan will run for 1 hour every day at a specified time.

### Water Manager

Select the preferred water management method:

- Salinity Measurement - replaces water when salinity level reaches set point.
- Timed Drain - drains the tank after 8 tank fill cycles or every 65 minutes (system dependant).
- No Drain Control - salinity control external to electronics eg. continuous bleed.
- No Water Thermostatic - allows thermostatic control in VENT mode. No water present. Cooling performance is limited.

### Weatherseal Open Speed

The cooler fan will turn on at the specified weatherseal opening speed for the first 10 seconds each time it starts up. It will then return to the set fan speed.

### Pre-wet

When COOL mode is activated, the pump will run for 90 seconds before the fan is switched on.

### Salinity Level

Sets the salinity level at which the tank will drain in "SALINITY MEASUREMENT" mode.

### Tank Drain Delay

Sets the time delay before the drain valve opens after the pump in the cooler is turned off.

### Autostart

Automatically restarts the cooler in the last operating mode after a power outage.

## FAULT CODES INDICATED BY LED'S ON THE COOLER ELECTRONICS MODULE

### Fault Code 01 (1 Red Flash) = Communication Failure.

- Ensure wall control cable is fitted correctly.
- Check the wall control cable is in good condition.

### Fault Code 02 (2 Red Flashes) = Failure to detect water at probes within 20 minutes.

- Ensure water pressure is sufficient to fill and maintain the tank to specified level within 20 minutes.
- In areas of hard or polluted water, blockage of the strainer/filter in the water inlet solenoid valve may restrict water flow.
- Water level set too low. For Braemar coolers the water level should be set to 5mm below the float valve base.
- Ensure probe plug is properly connected.
- Plug connections at electronic module are upside down or misaligned.
- Water too pure for the probes to sense water is present.
- Pressure build up in pipes can lock up the solenoid valve when a non-return isolation valve is used in the water supply line. It is recommended to use a ball valve, i.e. NOT a non-return type of shut off valve.
- Check drain valve is closing and not cycling due to debris being caught under drain valve washer.

### Fault Code 04 (4 Red Flashes) = Failure to clear probes during drain within 20 minutes.

- Check the drain valve opens and water drains from the tank, with nothing obstructing the outflow of water. (e.g. drain hose kinked)
- Excessive drain hose lengths or bends cause air locking and won't allow water to drain.
- Build up of foreign material in drain hose not allowing water to drain away correctly.
- Screws used to fix drain hoses to drain adaptors restricting water from draining from tank.
- Drain valve has failed to open when drain was initiated.
- Inlet water solenoid not shutting off water when the drain is open.
- Water will only flow one way through the inlet water solenoid valve. Therefore, it must be installed correctly. Directional arrow must be pointing towards the float valve assembly. If not, water will not shut off. (Directional arrow can be found on the bottom of the solenoid valve body).
- Debris interfering with water sensor probes.
- Probes not clipped onto mounting brackets correctly.
- Check cooler is level and water drains quickly.

### Fault Code 09 (9 Red Flashes) = Incorrect supply frequency (Hz).

#### (BMQ, CPQ, LCQ, TBQ and TBS coolers (CPMD) only)

This fault will only be seen when the mains power supply frequency deviates from normal frequency by more than 8%. Mains power supply frequency should be 50Hz. If the frequency deviates outside preset limits of 46-54Hz then this fault will be indicated.

- Petrol generators are the most likely cause of this type of fault. This typically will not occur on mains power supplies.

#### EXTRA NOTES FOR LPQI / TBQI / TBSI / LCQV / LPQV / TBQV / TBSV MODELS ONLY

### Fault Code 07 (7 Red Flashes) = Motor Error.

This fault is triggered when the inverter module cannot communicate with the control, re-connect the motor COMMS cable to electronics module and try to restart the cooler.

## TROUBLE SHOOTING

Symptom	Cause	Action
Inadequate cooling	Under-sized cooler.	Replace with larger cooler.
	Under-sized ducts.	Carry out cooling load design to determine correct size unit, ducting and outlets required.
	Clogged or dirty cooling pads.	Clean or replace pads.
	Dry pads or lack of water while cooler is operating.	Check water distribution system for possible obstruction in hoses. Check pump.
	Dry patches in pads (LPQI Models only)	Check for blockages inside the lid water distribution channels by lifting up the rubber channel cover. Clear out any debris.  Ensure the rubber channel cover is refitted and pressed down flush all the way around the lid before refitting pad frames or running the pump.
	Insufficient air discharge openings or inadequate exhaust from building, causing high humidity and discomfort.	Make sure there is adequate provision for exhausting stale air from building (open windows and doors).
	Excessive ambient humidity (see also item above re inadequate exhaust).	On days during summer when ambient humidity is high the cooler will not reduce the temperature as much as on drier days. There is no remedy except to shut off the pump.
Noisy cooler	Fan out of balance due to dirt, etc.	Clean the fan.
	Too much back pressure. Tight duct bends. Grilles too small.	Re-evaluate design; improve duct layout; change grille sizes.
Pump fails to operate.	Circuit breaker tripped.	Check pump for faults. Replace if necessary.
	Pump motor failure.	Replace pump.
Fan fails to start.	Main power circuit breaker tripped.	Check cause of overload. Reset circuit breaker.
	Fan motor burned out.	Replace motor.
	Low system voltage.	Consult with power supply authority.
	Check fault condition via the tri-colour LED on cooler electronics module.	Rectify fault as indicated and restart the cooler.
	Controller failure.	Replace controller.
Pump runs but no water circulation or Pump runs but pads lack water	Insufficient water in tank.	Adjust float level.
	Water hoses blocked.	Check and clean out blockage.
	Pump strainer blocked.	Clean pump strainer.
	Insufficient water supply pressure.	Check and confirm water supply pressure
	Water solenoid is installed incorrectly.	Check installed in the correct water flow direction
Continuous overflow of water.	Float valve adjustment not correct.	Adjust float valve.
	Heavy pad deposits.	Clean or replace pads.
	Drain valve failure.	Replace drain valve.
	Water solenoid is installed incorrectly.	Check installed in the correct water flow direction
Water entering cooler outlet.	Loose water hose connections.	Tighten connections.
	Water hose broken.	Replace cracked or broken hoses.
	Cover not fitted on float valve.	Replace float valve.
	Pads not fitted correctly into pad frames.	Install pad frame correctly.
	Incorrect or damaged pads.	Replace with new Chillcel pads.
Unpleasant odour.	New cooler pads.	Fill tank, run pump for a short period to wash pads, drain tank, refill and repeat several times if odour persists. Odour will dissipate after a number of hours of operation.
	Cooler located near source of unpleasant odour.	Remove source of odour or relocate cooler.
	Algae in tank water.	Drain pan, clean thoroughly with strong cleansing agent, refill, change pads.
	Pads remain wet after shut down.	Run fan on "vent" for 10 minutes after cooling cycle to dry pads out.
	Heavy pad deposits.	Clean or replace pads.



**Warranty Service**

Australia: 1300 650 644

New Zealand: 0800 589 151

**Seeley International Technical Support**

Australia: 1300 650 399

New Zealand: 0800 589 152

For all other regions, contact your local distributor:

**[seeleyinternational.com](http://seeleyinternational.com)**

**Online Support Portal (AUS/NZ)**

Scan or Click QR Code



It is the policy of Seeley International to introduce continuous product improvement.

Accordingly, specifications are subject to change without notice.

Please consult with your dealer to confirm the specifications of the model selected.